

Product Specification

IRB 6400

3HAC 4019-1
M98 / BW OS 3.2 / Rev. 1



S4Cplus



140



2400



1400



840



4400



340



6400S



640



6400PE



6400R

The information in this document is subject to change without notice and should not be construed as a commitment by ABB Robotics Products AB. ABB Robotics Products AB assumes no responsibility for any errors that may appear in this document.

In no event shall ABB Robotics Products AB be liable for incidental or consequential damages arising from use of this document or of the software and hardware described in this document.

This document and parts thereof must not be reproduced or copied without ABB Robotics Products AB's written permission, and contents thereof must not be imparted to a third party nor be used for any unauthorized purpose. Contravention will be prosecuted.

Additional copies of this document may be obtained from ABB Robotics Products AB at its then current charge.

© ABB Robotics Products AB

Article number: 3HAC 7677-1
Issue: M2000/Rev.1

ABB Robotics Products AB
S-721 68 Västerås
Sweden

CONTENTS

	Page
1 Introduction	3
2 Description	7
2.1 Structure.....	7
2.2 Safety/Standards	8
2.3 Operation	9
2.4 Installation	11
2.5 Programming	12
2.6 Automatic Operation	14
2.7 Maintenance and Troubleshooting	14
2.8 Robot Motion.....	16
2.9 External Axes	19
2.10 Inputs and Outputs.....	19
2.11 Communication.....	20
3 Technical specification	21
3.1 Structure.....	21
3.2 Safety/Standards	25
3.3 Operation	26
3.4 Installation	27
3.5 Programming	41
3.6 Automatic Operation	45
3.7 Maintenance and Troubleshooting	45
3.8 Robot Motion.....	46
3.9 External Axes	49
3.10 Inputs and Outputs.....	50
3.11 Communication.....	54
4 Specification of Variants and Options	55
5 Accessories	73
6 Index	75

1 Introduction

Thank you for your interest in the IRB 6400. This manual will give you an overview of the characteristics and performance of the robot.

IRB 6400 is a 6-axis industrial robot, designed specifically for manufacturing industries that use flexible robot-based automation. The robot has an open structure that is specially adapted for flexible use, and can communicate extensively with external systems.

The IRB 6400 comes in several different versions, with handling capacities of up to 250 kg, a maximum reach of 3 m, floor or shelf-mounted manipulators as well as manipulators for harsh environments.

Extra equipment, such as transformers and valve packages, can be placed on the upper arm or on the frame of axis 1 (see Chapter 3.4).

The robot is equipped with an operating system called BaseWare OS. BaseWare OS controls every aspect of the robot, like motion control, development and execution of application programs, communication etc.

The functions in this document are all included in BaseWare OS, if not otherwise specified. For additional functionality the robot can be equipped with optional software for application support - spot welding, gluing for example, communication features - network communication and advanced functions - multitasking, sensor control etc. For a complete description of optional software, see the Product Specification RobotWare.

All the features are not described in this document. For a more complete and detailed description, please see the User's Guide, RAPID Reference Manual and Product Manual, or contact your nearest ABB Flexible Automation Centre.

Accessories, such as track motion, base plates, motors for external axes, cabling for spot welding guns, and tool systems with tool exchangers, have been specially adapted for use with the IRB 6400 (see Chapter 5).

Introduction

Different robot versions

The IRB 6400, as mentioned above, is available in several different versions. The following different robot types are available:

Robot Versions	
IRB 6400/ 2.4-120	IRB 6400F/ 2.4-120
IRB 6400/ 2.4-150	IRB 6400F/ 2.4-150
IRB 6400/ 2.4-200	IRB 6400F/ 2.4-200
IRB 6400/ 2.8-120	IRB 6400F/ 2.8-120
IRB 6400/ 3.0-75	IRB 6400F/ 3.0-75
IRB 6400S/ 2.9-120	IRB 6400FS/ 2.9-120
IRB 6400PE/ 2.25 -75	IRB 6400FHD

Definition of version designation

IRB 6400 Application, Mounting/ Reach - Handling capacity

	Prefix	Description
Application	PE	Robot adapted for poke welding
	F	Manipulator adapted for use in harsh environments (e.g. foundry)
	HD	Heavy Duty
Mounting	-	Floor-mounted manipulator
	S	Shelf-mounted manipulator
Reach	x.x	Indicates the maximum reach at wrist centre (m)
Handling capacity	yyy	Indicates the maximum handling capacity (kg)

How to use this manual

The characteristics of the robot are described in Chapter 2: *Description*.

The most important technical data is listed in Chapter 3: *Technical specification*.

Note that the sections in chapters 2 and 3 are related to each other. For example, in section 2.2 you can find an overview of safety and standards, in section 3.2 you can find more detailed information.

To make sure that you have ordered a robot with the correct functionality, see Chapter 4: *Specification of Variants and Options*.

In Chapter 5 you will find accessories for the robot.

Chapter 6 contains an *Index*, to make things easier to find.

Other manuals

The User's Guide is a reference manual with step by step instructions on how to perform various tasks.

The programming language is described in the RAPID Reference Manual.

The Product Manual describes how to install the robot, as well as maintenance procedures and troubleshooting.

The Product Specification RobotWare describes the software options.

Introduction

2 Description

2.1 Structure

The robot is made up of two main parts: a manipulator and a controller.

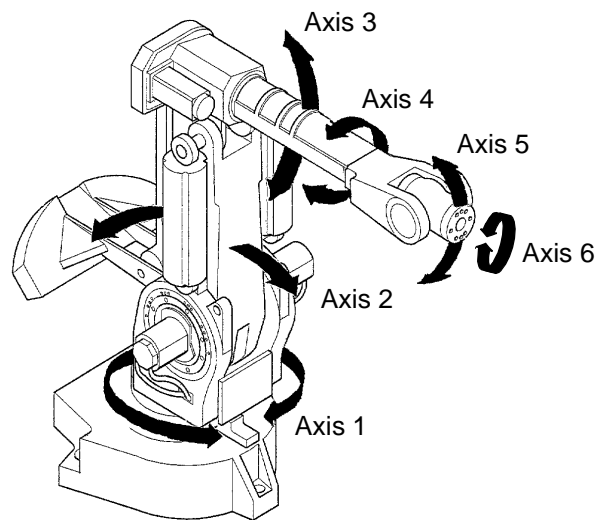

Figure 1 The IRB 6400 manipulator has 6 axes.

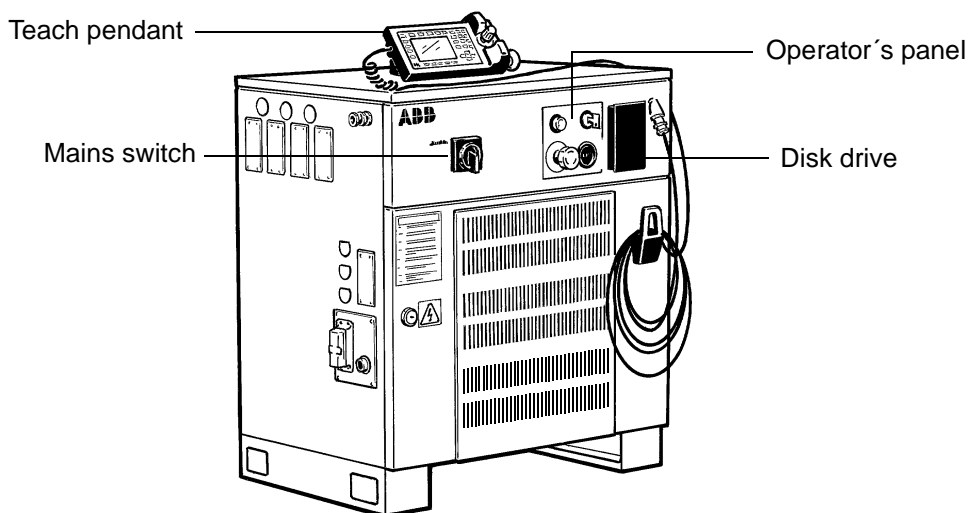

Figure 2 The controller is specifically designed to control robots, which means that optimal performance and functionality is achieved.

The controller contains the electronics required to control the manipulator, external axes and peripheral equipment.

2.2 Safety/Standards

The robot complies fully with the health and safety standards specified in the EEC's Machinery Directives as well as ANSI/RIA 15.06-1992.

The robot is designed with absolute safety in mind. It has a dedicated safety system based on a two-channel circuit which is monitored continuously. If any component fails, the electrical power supplied to the motors shuts off and the brakes engage.

Safety category 3

Malfunction of a single component, such as a sticking relay, will be detected at the next MOTOR OFF/MOTOR ON operation. MOTOR ON is then prevented and the faulty section is indicated. This complies with category 3 of EN 954-1, Safety of machinery - safety related parts of control systems - Part 1.

Selecting the operating mode

The robot can be operated either manually or automatically. In manual mode, the robot can only be operated via the teach pendant, i.e. not by any external equipment.

Reduced speed

In manual mode, the speed is limited to a maximum of 250 mm/s (600 inch/min.). The speed limitation applies not only to the TCP (Tool Centre point), but to all parts of the robot. It is also possible to monitor the speed of equipment mounted on the robot.

Three position enabling device

The enabling device on the teach pendant must be used to move the robot when in manual mode. The enabling device consists of a switch with three positions, meaning that all robot movements stop when either the enabling device is pushed fully in, or when it is released completely. This makes the robot safer to operate.

Safe manual movement

The robot is moved using a joystick instead of the operator having to look at the teach pendant to find the right key.

Over-speed protection

The speed of the robot is monitored by two independent computers.

Emergency stop

There is one emergency stop push button on the controller and another on the teach pendant. Additional emergency stop buttons can be connected to the robot's safety chain circuit.

Safeguarded space stop

The robot has a number of electrical inputs which can be used to connect external safety equipment, such as safety gates and light curtains. This allows the robot's safety functions to be activated both by peripheral equipment and by the robot itself.

Delayed safeguarded space stop

A delayed stop gives a smooth stop. The robot stops in the same way as at a normal program stop with no deviation from the programmed path. After approx. 1 second the power supplied to the motors shuts off.

Restricting the working space

The movement of each axis can be restricted using software limits. Axes 1-3 can also be restricted by means of mechanical stops.

Hold-to-run control

“Hold-to-run” means that you must depress the start button in order to move the robot. When the button is released the robot will stop. The hold-to-run function makes program testing safer.

Fire safety

Both the manipulator and control system comply with UL’s (Underwriters Laboratory) tough requirements for fire safety.

Safety lamp

As an option, the robot can be equipped with a safety lamp mounted on the manipulator. This is activated when the motors are in the MOTORS ON state.

2.3 Operation

All operations and programming can be carried out using the portable teach pendant (see Figure 3) and the operator’s panel (see Figure 5).

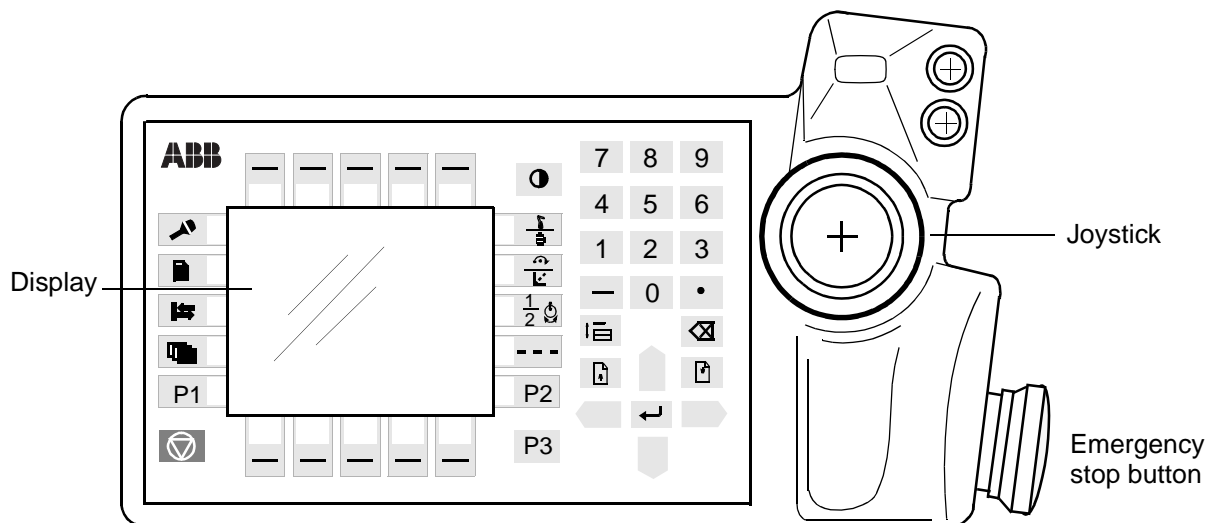

Figure 3 The teach pendant is equipped with a large display, which displays prompts, information, error messages and other information in plain English.

Information is presented on a display using windows, pull-down menus, dialogs and function keys. No previous programming or computer experience is required to learn how to operate the robot. All operations can be carried out from the teach pendant, which means that an additional keyboard is not required. All information, including the complete programming language, is in English or, if preferred, some other major language. (For a list of languages, see Product Specification RobotWare.)

Description

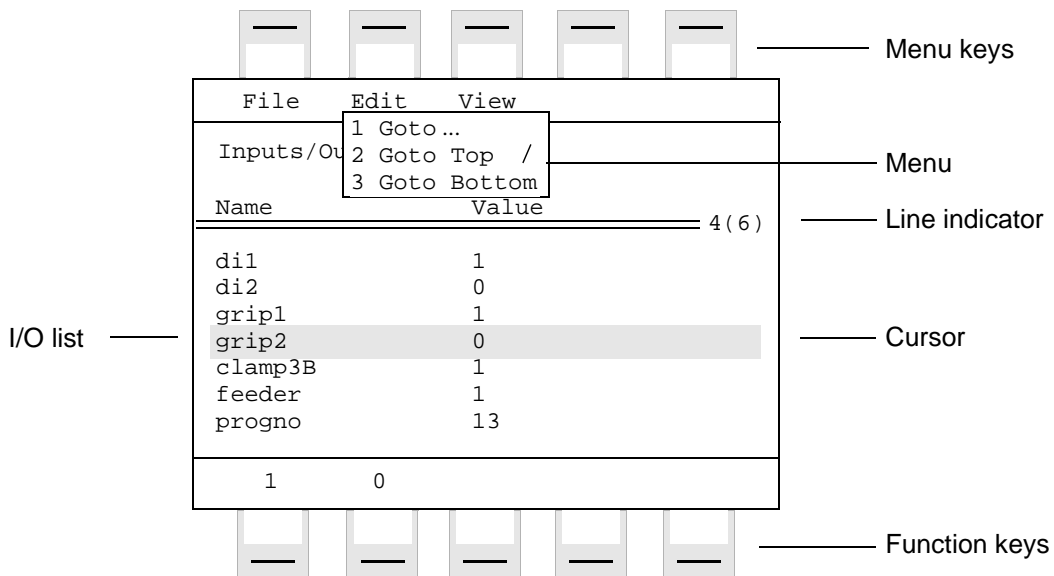

Figure 4 Window for manual operation of input and output signals.

Using the joystick, the robot can be manually jogged (moved). The user determines the speed of this movement; large deflections of the joystick will move the robot quickly, smaller deflections will move it more slowly.

The robot supports different user tasks, with dedicated windows for:

- Production
- Programming
- System setup
- Service and installation

Operator's panel

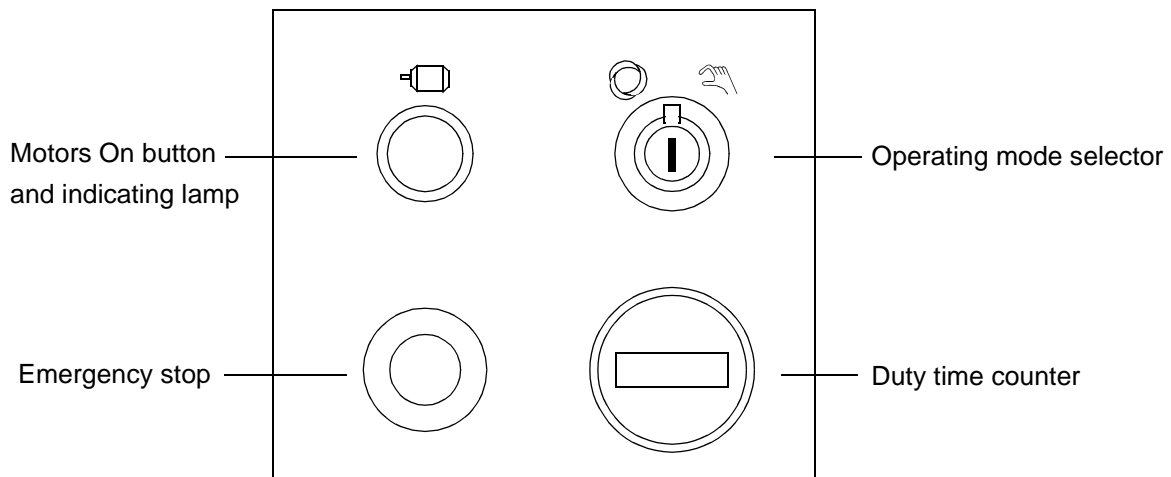





Figure 5 The operating mode is selected using the operator's panel on the controller.

Using a key switch, the robot can be locked in two or three different operating modes depending on chosen mode selector:

-  • Automatic mode: Running production
 -  • Manual mode at reduced speed: Programming and setup
Max. speed: 250 mm/s (600 inches/min.)
 - 100%  • Manual mode at full speed (option): Testing at full program speed
-  Equipped with this mode, the robot is not approved according to ANSI/UL

Both the operator's panel and the teach pendant can be mounted externally, i.e. outside the cabinet. The robot can then be controlled from there.

The robot can be remotely controlled from a computer, PLC or from a customer's panel, using serial communication or digital system signals.

For more information on how to operate the robot, see the User's Guide.

2.4 Installation

The robot has a standard configuration and can be operated immediately after installation. Its configuration is displayed in plain language and can easily be changed using the teach pendant. The configuration can be stored on a diskette and/or transferred to other robots that have the same characteristics.

All the versions of IRB 6400 are designed for floor mounting except one version for shelf-mounting. Depending on the robot version an end effector of max. weight 75 to 250 kg, including payload, can be mounted on the mounting flange (axis 6). Load diagram, see chapter 3.4.

Extra loads (valve packages, transformers) can be mounted on the upper arm. On all versions, an extra load can also be mounted on the frame of axis 1. Holes for extra equipment are described in chapter 3.4.

The working range of axes 1-3 can be limited by mechanical stops. Position switches can be supplied on axis 1 and axis 2 for position indication of the manipulator (see Chapter 4).

2.5 Programming

Programming the robot involves choosing instructions and arguments from lists of appropriate alternatives. Users do not need to remember the format of instructions, since they are prompted in plain English. “See and pick” is used instead of “remember and type”.

The programming environment can be easily customized using the teach pendant.

- Shop floor language can be used to name programs, signals, counters, etc.
- New instructions can be easily written.
- The most common instructions can be collected in easy-to-use pick lists.
- Positions, registers, tool data, or other data, can be created.

Programs, parts of programs and any modifications can be tested immediately without having to translate (compile) the program.

The program is stored as a normal PC text file, which means that it can be edited using a standard PC.

Movements

A sequence of movements is programmed as a number of partial movements between the positions to which you want the robot to move.

The end position of a movement is selected either by manually jogging the robot to the desired position with the joystick, or by referring to a previously defined position.

The exact position can be defined (see Figure 6) as:

- a stop point, i.e. the robot reaches the programmed position

or

- a fly-by point, i.e. the robot passes close to the programmed position. The size of the deviation is defined independently for the TCP, the tool orientation and the external axes.

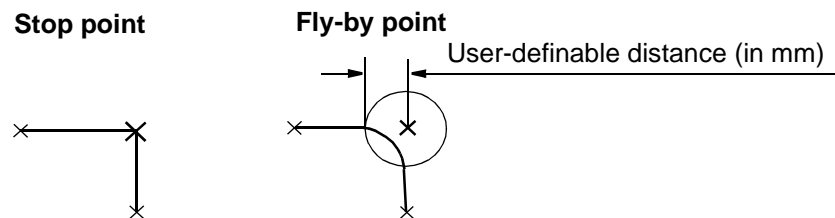

Figure 6 The fly-by point reduces the cycle time since the robot does not have to stop at the programmed point. The path is speed independent.

The velocity may be specified in the following units:

- mm/s
- seconds (time it takes to reach the next programmed position)
- degrees/s (for reorientation of the tool or for rotation of an external axis)

Program management

For convenience, the programs can be named and stored in different directories.

Areas of the robot's program memory can also be used for program storage. This provides fast memory for program storage. These can then be automatically downloaded using a program instruction. The complete program or parts of programs can be transferred to/from a diskette.

Programs can be printed on a printer connected to the robot, or transferred to a PC where they can be edited or printed later.

Editing programs

Programs can be edited using standard editing commands, i.e. "cut-and-paste", copy, delete, find and change, undo etc. Individual arguments in an instruction can also be edited using these commands.

No reprogramming is necessary when processing left-hand and right-hand parts, since the program can be mirrored in any plane.

A robot position can easily be changed either by

- jogging the robot with the joystick to a new position and then pressing the "ModPos" key (this registers the new position)

or by

- entering or modifying numeric values.

To prevent unauthorised personnel from making program changes, passwords can be used.

Testing programs

Several helpful functions can be used when testing programs. For example, it is possible to

- start from any instruction
- execute an incomplete program
- run a single cycle
- execute forward/backward step-by-step
- simulate wait conditions
- temporarily reduce the speed
- change a position
- tune (displace) a position during program execution.

For more information, see the User's Guide and RAPID Reference Manual.

2.6 Automatic Operation

A dedicated production window with commands and information required by the operator is automatically displayed during automatic operation.

The operation procedure can be customised to suit the robot installation by means of user-defined operating dialogs.

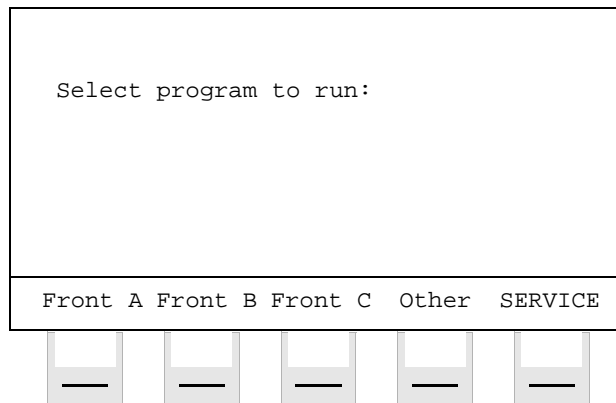

Figure 7 The operator dialogs can be easily customised.

A special input can be set to order the robot to go to a service position. After service, the robot is ordered to return to the programmed path and continue program execution.

You can also create special routines that will be automatically executed when the power is switched on, at program start and on other occasions. This allows you to customise each installation and to make sure that the robot is started up in a controlled way.

The robot is equipped with absolute measurement, making it possible to operate the robot directly when the power is switched on. For your convenience, the robot saves the used path, program data and configuration parameters so that the program can be easily restarted from where you left off. Digital outputs are also set automatically to the value prior to the power failure.

2.7 Maintenance and Troubleshooting

The robot requires only a minimum of maintenance during operation. It has been designed to make it as easy to service as possible:

- The controller is enclosed, which means that the electronic circuitry is protected when operating in a normal workshop environment.
- Maintenance-free AC motors are used.
- Liquid grease or oil is used for the gear boxes.
- The cabling is routed for longevity, and in the unlikely event of a failure, its modular design makes it easy to change.
- It has a program memory “battery low” alarm.

The robot has several functions to provide efficient diagnostics and error reports:

- It performs a self-test when power on is set.
- Errors are indicated by a message displayed in plain language.
The message includes the reason for the fault and suggests recovery action.
- A board error is indicated by a LED on the faulty unit.
- Faults and major events are logged and time-stamped. This makes it possible to detect error chains and provides the background for any downtime. The log can be read on the teach pendant display, stored in a file or printed on a printer.
- There are commands and service programs in RAPID to test units and functions.

Most errors detected by the user program can also be reported to and handled by the standard error system. Error messages and recovery procedures are displayed in plain language.

2.8 Robot Motion

Floor-mounting

Dimensions apply to
IRB 6400/ 3.0-75

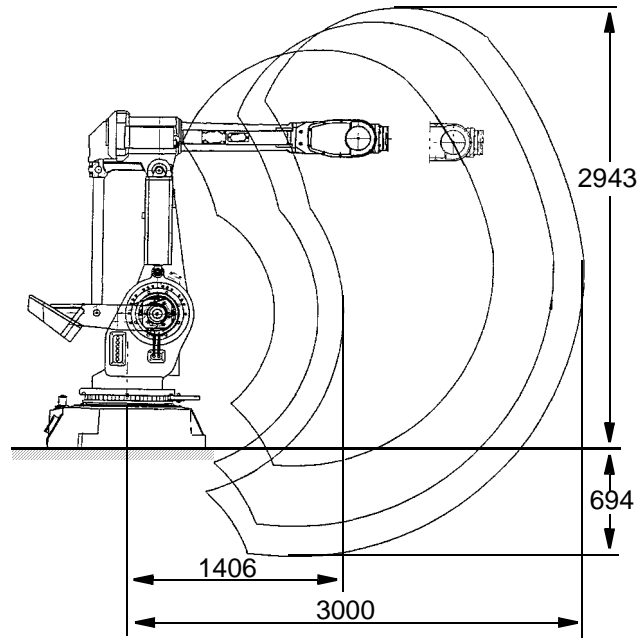

Shelf-mounting

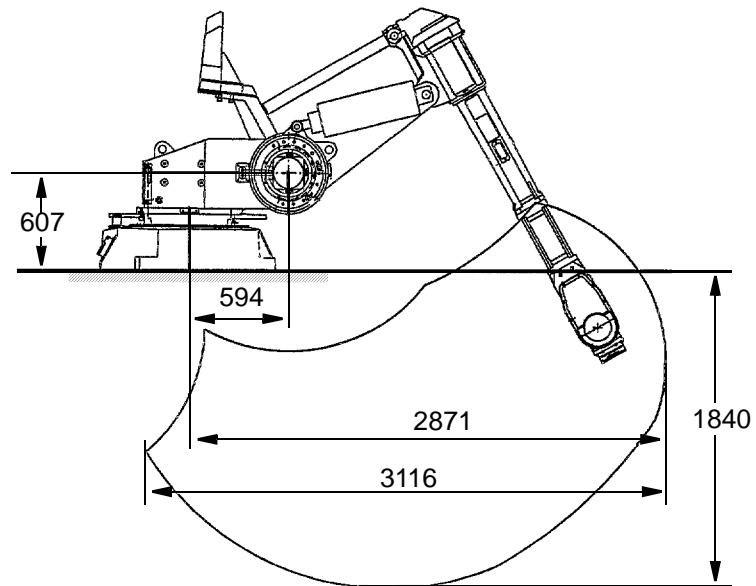

Figure 8 Working space of IRB 6400 and IRB 6400S (dimensions in mm).

Motion performance

The QuickMove™ concept means that a self-optimizing motion control is used. The robot automatically optimizes the servo parameters to achieve the best possible performance throughout the cycle – based on load properties, location in working area, velocity and direction of movement.

- No parameters have to be adjusted to achieve correct path, orientation and velocity.
- Maximum acceleration is always obtained (acceleration can be reduced, e.g. when handling fragile parts).
- The number of adjustments that have to be made to achieve the shortest possible cycle time is minimized.

The TrueMove™ concept means that the programmed path is followed – regardless of the speed or operating mode – even after an emergency stop, a safeguarded stop, a process stop, a program stop or a power failure.

The robot can, in a controlled way, pass through singular points, i.e. points where two axes coincide.

Coordinate systems

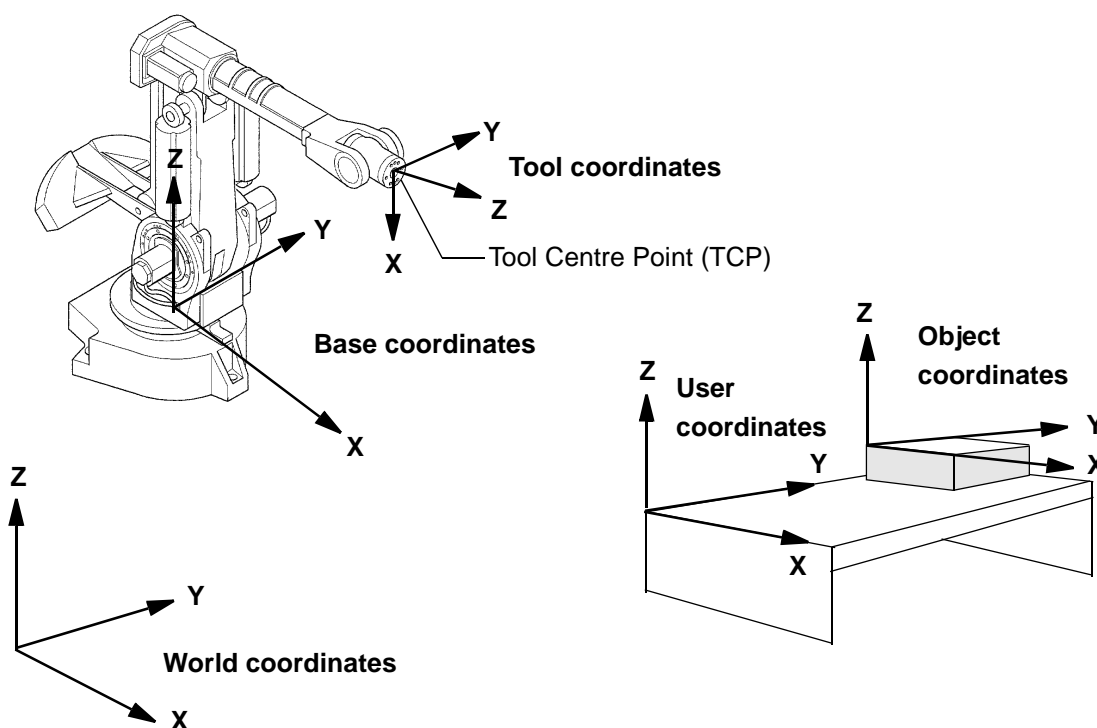

Figure 9 The coordinate systems, used to make jogging and off-line programming easier.

The world coordinate system defines a reference to the floor, which is the starting point for the other coordinate systems. Using this coordinate system, it is possible to relate the robot position to a fixed point in the workshop. The world coordinate system is also very useful when two robots work together or when using a robot carrier.

The base coordinate system is attached to the base mounting surface of the robot.

The tool coordinate system specifies the tool's centre point and orientation.

Description

The user coordinate system specifies the position of a fixture or workpiece manipulator.

The object coordinate system specifies how a workpiece is positioned in a fixture or workpiece manipulator.

The coordinate systems can be programmed by specifying numeric values or jogging the robot through a number of positions (the tool does not have to be removed).

Each position is specified in object coordinates with respect to the tool's position and orientation. This means that even if a tool is changed because it is damaged, the old program can still be used, unchanged, by making a new definition of the tool.

If a fixture or workpiece is moved, only the user or object coordinate system has to be redefined.

Stationary TCP

When the robot is holding a work object and working on a stationary tool, it is possible to define a TCP for that tool. When that tool is active, the programmed path and speed are related to the work object.

Program execution

The robot can move in any of the following ways:

- Joint motion (all axes move individually and reach the programmed position at the same time)
- Linear motion (the TCP moves in a linear path)
- Circle motion (the TCP moves in a circular path)

Soft servo - allowing external forces to cause deviation from programmed position - can be used as an alternative to mechanical compliance in grippers, where imperfection in processed objects can occur.

If the location of a workpiece varies from time to time, the robot can find its position by means of a digital sensor. The robot program can then be modified in order to adjust the motion to the location of the part.

Jogging

The robot can be manually operated in any one of the following ways:

- Axis-by-axis, i.e. one axis at a time
- Linearly, i.e. the TCP moves in a linear path (relative to one of the coordinate systems mentioned above)
- Reoriented around the TCP

It is possible to select the step size for incremental jogging. Incremental jogging can be used to position the robot with high precision, since the robot moves a short distance each time the joystick is moved.

During manual operation, the current position of the robot and the external axes can be displayed on the teach pendant.

2.9 External Axes

The robot can control up to six external axes. These axes are programmed and moved using the teach pendant in the same way as the robot's axes.

The external axes can be grouped into mechanical units to facilitate, for example, the handling of robot carriers, workpiece manipulators, etc.

The robot motion can be simultaneously coordinated with for example, a one-axis linear robot carrier and a rotational external axis.

A mechanical unit can be activated or deactivated to make it safe when, for example, manually changing a workpiece located on the unit. In order to reduce investment costs, any axes that do not have to be active at the same time, can share the same drive unit.

2.10 Inputs and Outputs

A distributed I/O system is used, which makes it possible to mount the I/O units either inside the cabinet or outside the cabinet with a cable connecting the I/O unit to the cabinet.

A number of different input and output units can be installed:

- Digital inputs and outputs.
- Analog inputs and outputs.
- Remote I/O for Allen-Bradley PLC.
- InterBus-S Slave.
- Profibus DP Slave.

The inputs and outputs can be configured to suit your installation:

- Each signal and unit can be given a name, e.g. gripper, feeder.
- I/O mapping (i.e. a physical connection for each signal).
- Polarity (active high or low).
- Cross connections.
- Up to 16 digital signals can be grouped together and used as if they were a single signal when, for example, entering a bar code.

Signals can be assigned to special system functions, such as program start, so as to be able to control the robot from an external panel or PLC.

The robot can work as a PLC by monitoring and controlling I/O signals:

- I/O instructions can be executed concurrent to the robot motion.
- Inputs can be connected to trap routines. (When such an input is set, the trap routine starts executing. Following this, normal program execution resumes. In most cases, this will not have any visible effect on the robot motion, i.e. if a limited number of instructions are executed in the trap routine.)
- Background programs (for monitoring signals, for example) can be run in parallel with the actual robot program. Requires Multitasking option, see Product Specification RobotWare.

Description

Manual functions are available to:

- List all the signal values.
- Create your own list of your most important signals.
- Manually change the status of an output signal.
- Print signal information on a printer.

I/O signals can also be routed to connectors on the upper arm of the robot.

2.11 Communication

The robot can communicate with computers or other equipment via RS232/RS422 serial channels or via Ethernet. However this requires optional software, see Product Specification RobotWare.

3 Technical specification

Applies to standard and Foundry versions unless otherwise stated.

3.1 Structure

Weight:	Manipulator	IRB 6400PE /2.25-75	1590 kg
		IRB 6400 /2.4-120	1910 kg
		IRB 6400 /2.4-150, /2.4-200	
		/2.8-120, /3.0-75	2050 kg
		IRB 6400FHD	2050 kg
Controller		IRB 6400S /2.9-120	2240 kg
			240 kg

Volume: Controller 950 x 800 x 540 mm

Airborne noise level:

The sound pressure level outside the working space < 70 dB (A) Leq (acc. to Machinery directive 89/392 EEC)

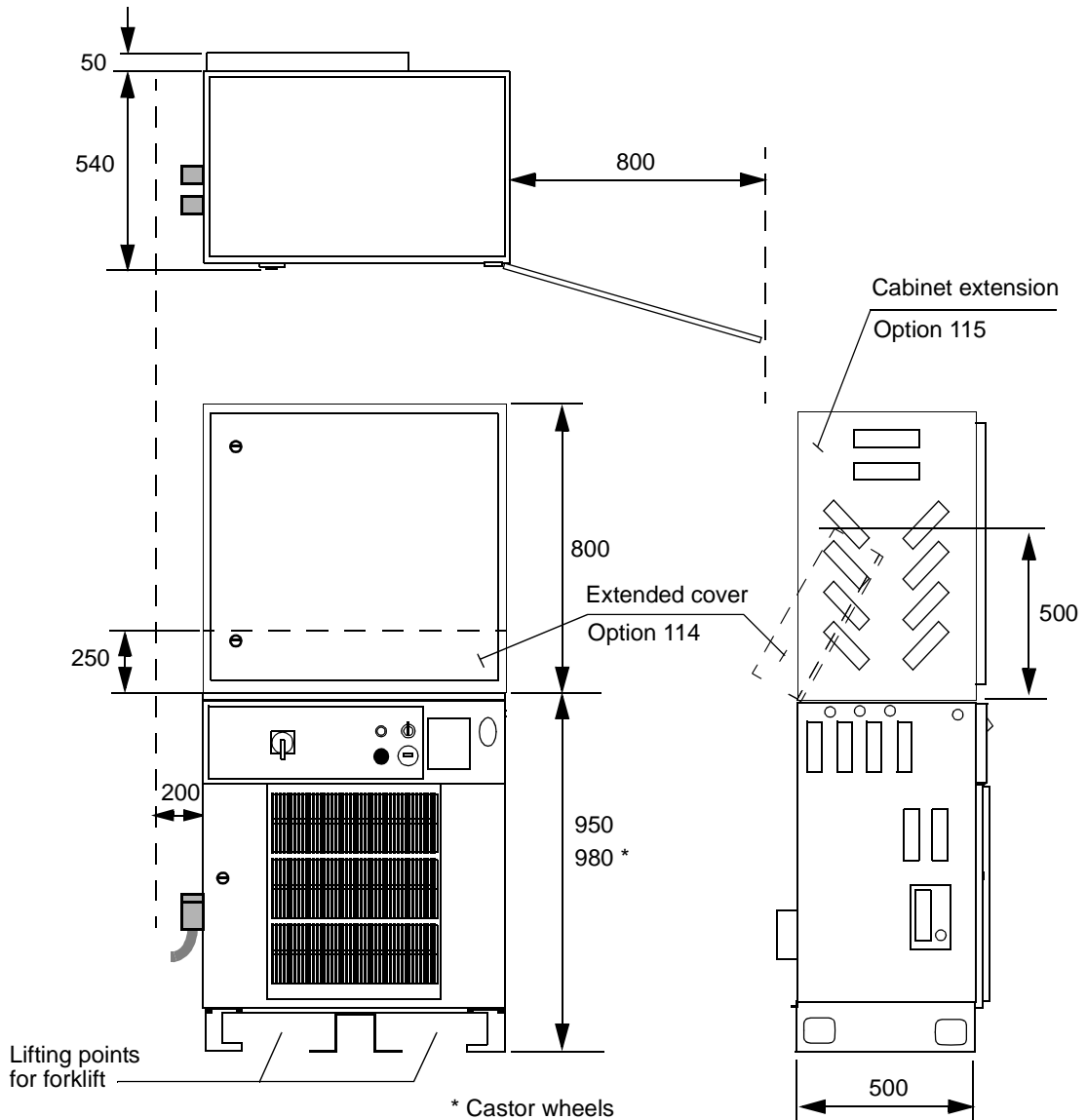

Figure 10 View of the controller from the front, from above and from the side (dimensions in mm).

Technical specification

**IRB 6400 /2.4-120, /2.4-150, /2.4-200, /2.8-120, /3.0-75
IRB 6400FHD**

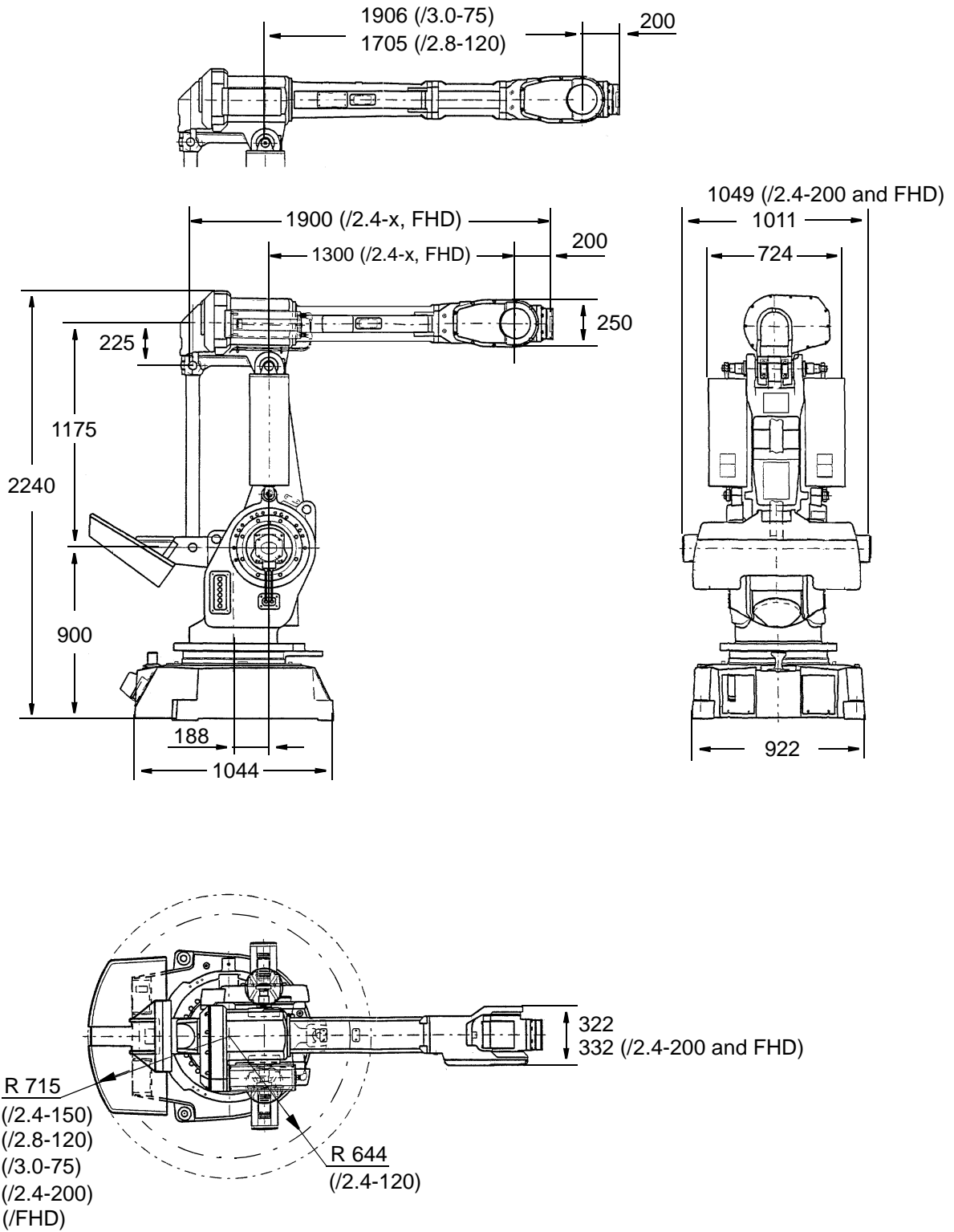

Figure 11 View of the manipulator from the side, rear and above (dimensions in mm).

IRB 6400PE /2.25-75

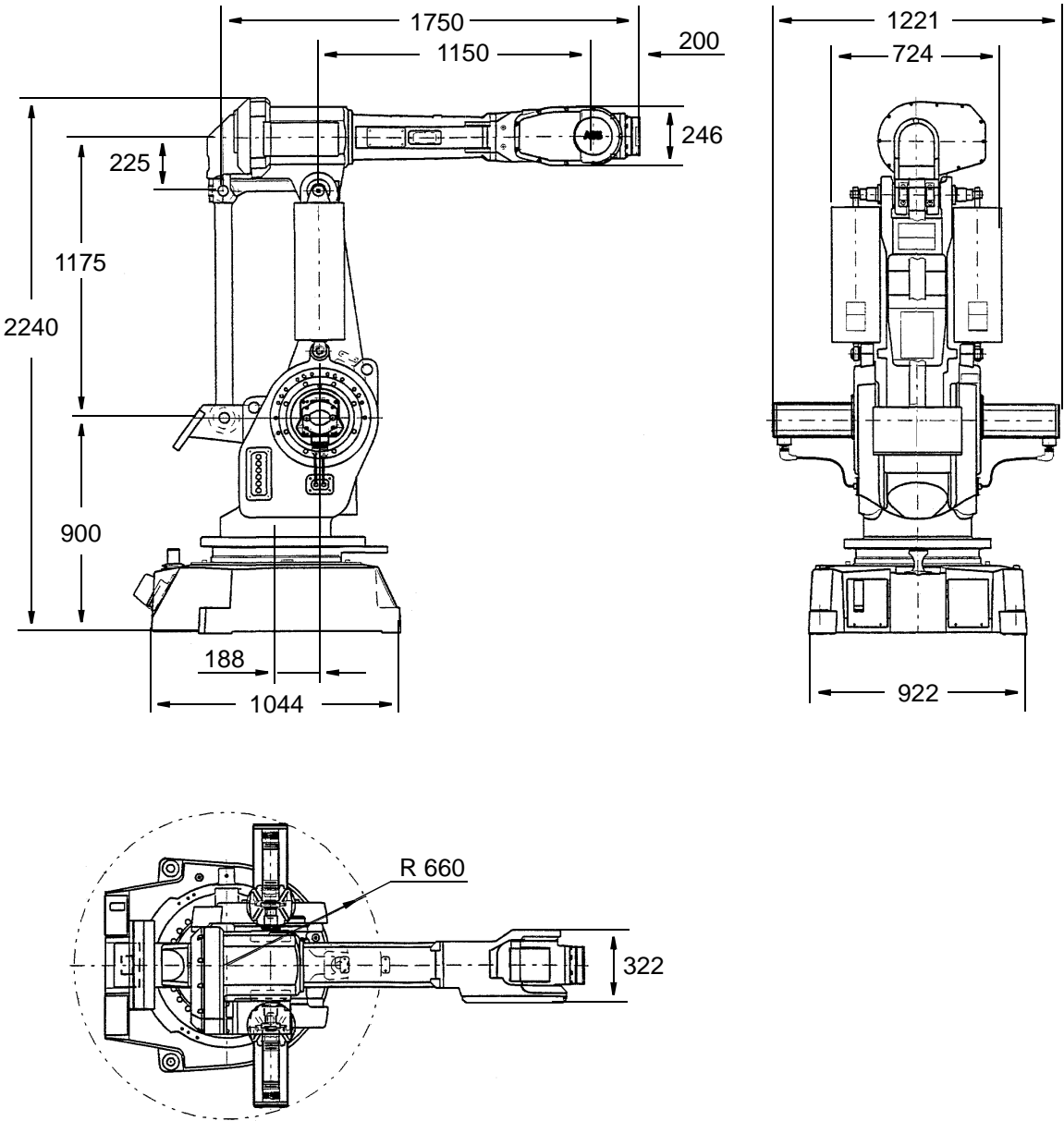

Figure 12 View of the manipulator from the side, rear and above (dimensions in mm).

Technical specification

IRB 6400S /2.9-120

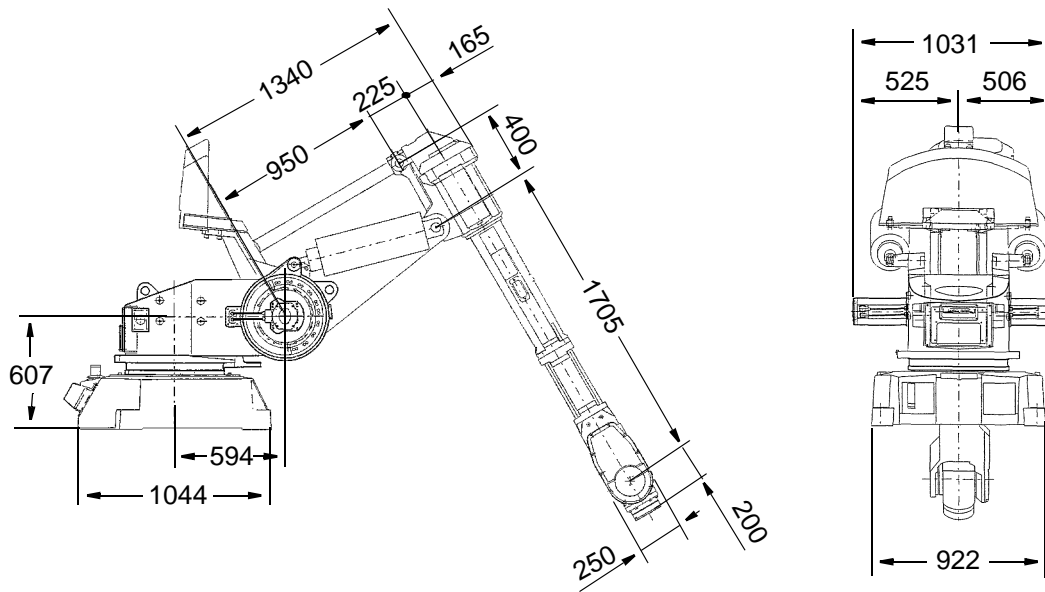

Figure 13 View of the manipulator from the side and rear (dimensions in mm).
The robot is shown in its calibration position.

3.2 Safety/Standards

The robot conforms to the following standards:

EN 292-1	Safety of machinery, terminology
EN 292-2	Safety of machinery, technical specifications
EN 954-1	Safety of machinery, safety related parts of control systems
EN 60204 ¹	Electrical equipment of industrial machines
IEC 204-1	Electrical equipment of industrial machines
ISO 10218, EN 775	Manipulating industrial robots, safety
ANSI/RIA 15.06/1992	Industrial robots, safety requirements
ISO 9409-1	Manipulating industrial robots, mechanical interface
ISO 9787	Manipulating industrial robots, coordinate systems and motions
IEC 529	Degrees of protection provided by enclosures
EN 50081-2	EMC, Generic emission
EN 50082-2	EMC, Generic immunity
ANSI/UL 1740-1996 (option)	Standard for Industrial Robots and Robotic Equipment
CAN/CSA Z 434-94 (option)	Industrial Robots and Robot Systems - General Safety Requirements

Safeguarded space stops via inputs

External safety equipment can be connected to the robot's two-channel emergency stop chain in several different ways (see Figure 14).

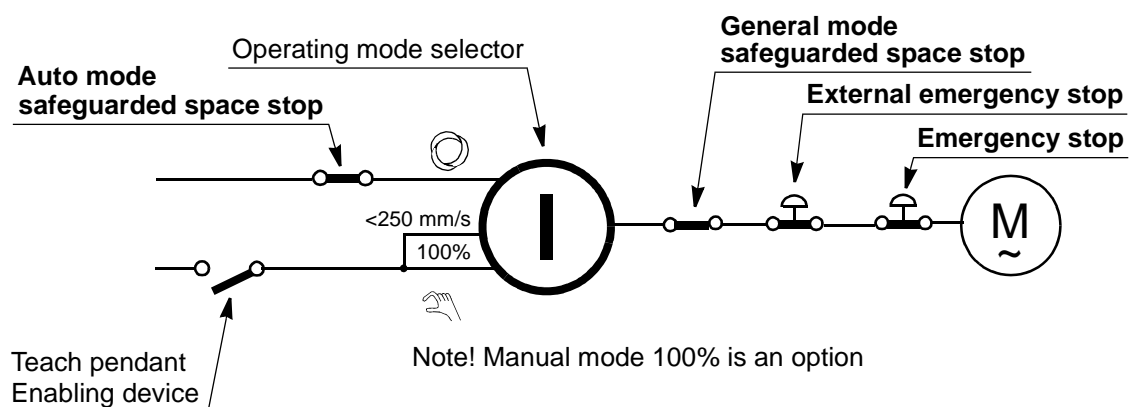

Figure 14 All safeguarded space stops force the robot's motors to the MOTORS OFF state. A time delay can be used on the emergency stops or any safeguarded space stops.

1. There is a deviation from the extra demand for only electromechanical components on emergency stop of category 0 in paragraph 9.2.5.4. EN 60204-1 accepts one channel circuit without monitoring, instead the design is made to comply with category 3 according to EN 954-1, where the demand for redundancy is founded.

3.3 Operation

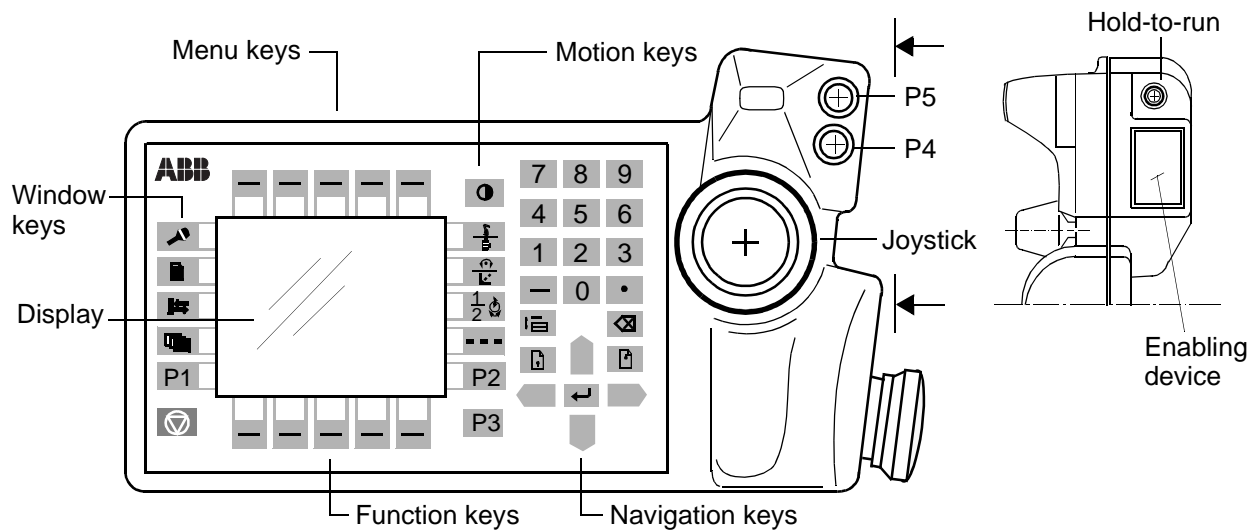

Figure 15 The teach pendant is very easy to use since any functions provided via the function and menu keys are described in plain language. The remaining keys can perform only one function each.

Display

16 text lines with 40 characters per line.

Motion keys

Select the type of movement when jogging.

Navigation keys

Move the cursor and enter data.

Menu keys

Display pull-down menus.

Function keys

Select the commands used most often.

Window keys

Display one of the robot's various windows. These windows control a number of IRB 6400 different functions:

- Jog (manual operation)
- Program, edit and test a program
- Manual input/output management
- File management
- System configuration
- Service and troubleshooting
- Automatic operation

User-defined keys (P1-P5)

Five user-defined keys that can be configured to set or reset an output (e.g. open/close gripper) or to activate a system input (see chapter 3.10).

3.4 Installation

Operating requirements

Protection standards		IEC529
	Manipulator	IP54
	Wrist	IP55
	Controller	IP54
IRB 6400F	Manipulator	IP55
	Upper arm	IP66
	Wrist	IP67
	Controller	IP54

Explosive environments

The robot must not be located or operated in an explosive environment.

Ambient temperature

Manipulator during operation	+5°C (41°F) to +45°C (117°F)
Controller during operation	+5°C (41°F) to +52°C (125°F)
Complete robot during transportation and storage, for short periods (not exceeding 24 hours)	-25°C (13°F) to +55°C (131°F) up to +70°C (158°F)

Relative humidity

Complete robot during transportation and storage	Max. 95% at constant temperature
Complete robot during operation	Max. 95% at constant temperature

Power supply

Mains voltage	200-600V, 3p (3p + N for certain options, +10%,-15%)
Mains frequency	48.5 to 61.8 Hz
Rated power	7.2 kVA - 14.4 kVA
Rated power (IRB 6400PE)	8.3 kVA - 15.5 kVA
Absolute measurement backup	1000 h (rechargeable battery)

Configuration

The robot is very flexible and can, by using the teach pendant, easily be configured to suit the needs of each user:

Authorisation	Password protection for configuration and program window
Most common I/O	User-defined lists of I/O signals
Instruction pick list	User-defined set of instructions
Instruction builder	User-defined instructions
Operator dialogs	Customised operator dialogs
Language	All text on the teach pendant can be displayed in several languages

Technical specification

Date and time	Calendar support
Power on sequence	Action taken when the power is switched on
EM stop sequence	Action taken at an emergency stop
Main start sequence	Action taken when the program is starting from the beginning
Program start sequence	Action taken at program start
Program stop sequence	Action taken at program stop
Change program sequence	Action taken when a new program is loaded
Working space	Working space limitations
External axes	Number, type, common drive unit, mechanical units
Brake delay time	Time before brakes are engaged
I/O signal	Logical names of boards and signals, I/O mapping, cross connections, polarity, scaling, default value at start up, interrupts, group I/O
Serial communication	Configuration

For a detailed description of the installations procedure, see the Product Manual - Installation and Commissioning.

Mounting the manipulator

Maximum load in relation to the base coordinate system.

	Endurance load in operation	Max. load at emergency stop
Force xy	± 12000 N	± 18000 N
Force z	21000 ± 5500 N	21000 ± 10000 N
Torque xy	± 32000 Nm	± 39000 Nm
Torque z	± 6000 Nm	± 13000 Nm
Torque z PE/2.25-75	± 12000 Nm	

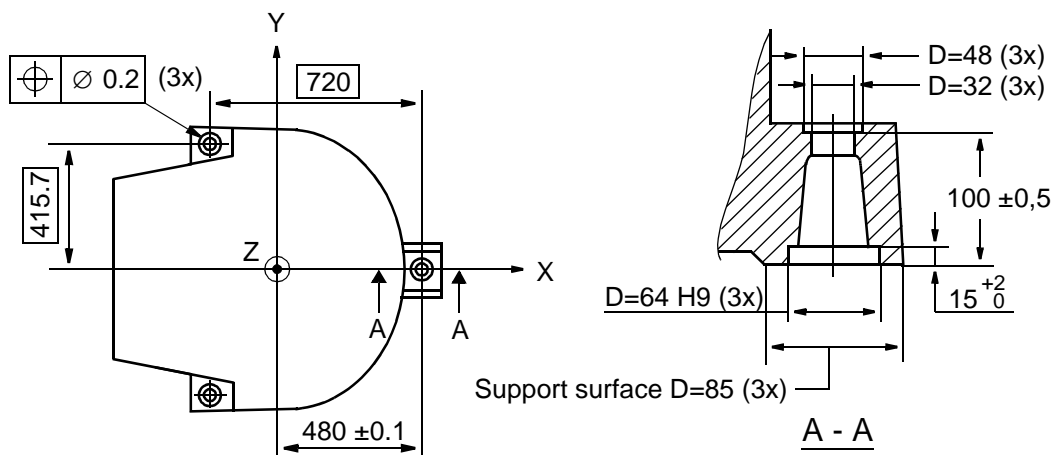
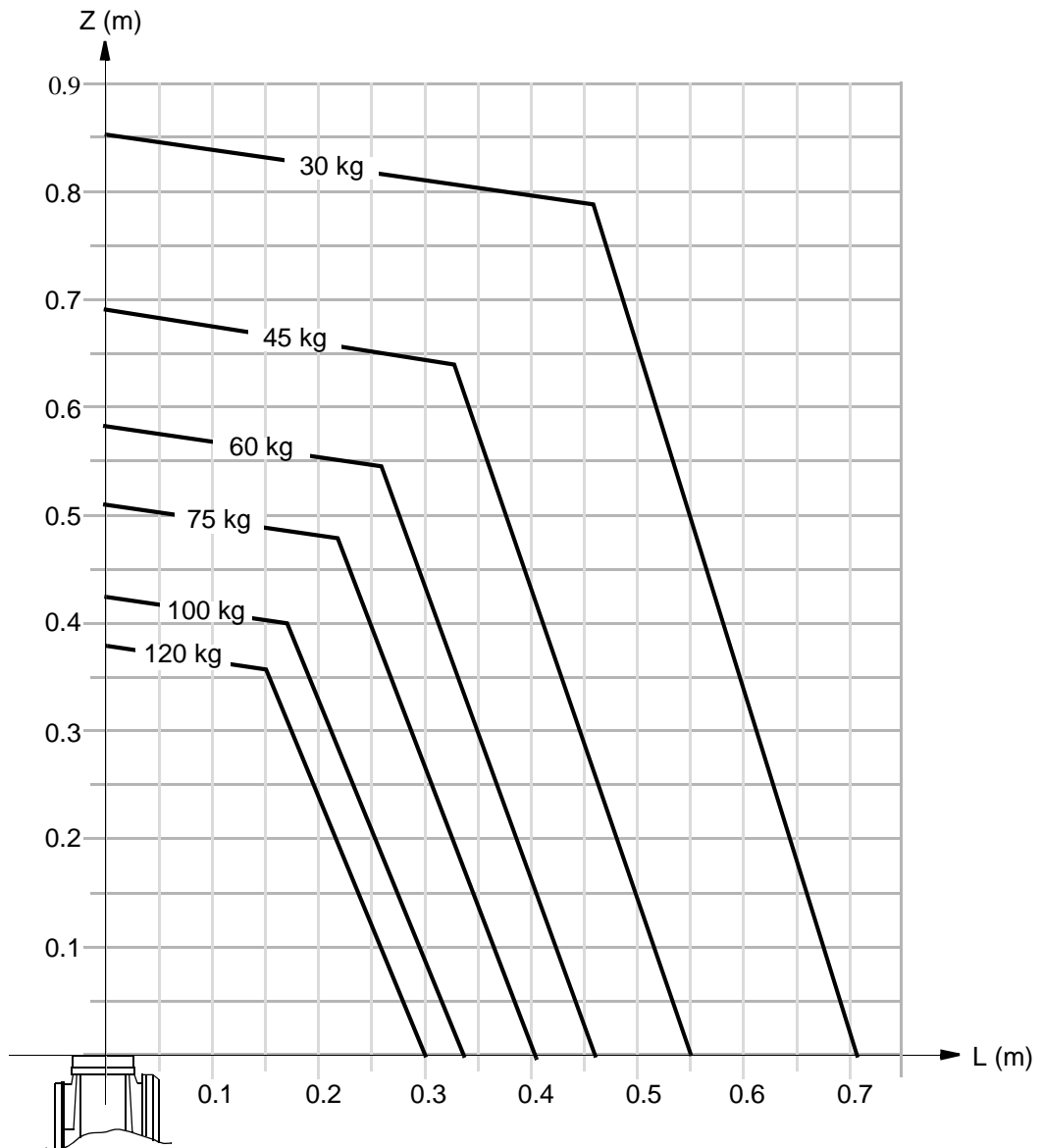

Figure 16 Hole configuration (dimensions in mm).

Load diagrams

Load diagram for **IRB 6400 /2.4-120, IRB 6400 /2.8-120, IRB 6400 /3.0-75 and IRB 6400S /2.9-120**

(The curves for 100 and 120 kg are not valid for /3.0-75, max. handling capacity limited to 75 kg).



The load diagram is valid for $J_0 < 100 \text{ kgm}^2$.
 J_0 = the maximum component (J_{x0} , J_{y0} , J_{z0}) of the moment of inertia of the handling weight at its centre of gravity.

Figure 17 Maximum weight permitted for load mounted on the mounting flange at different positions (centre of gravity).

Technical specification

Load diagram for IRB 6400 /2.4-150

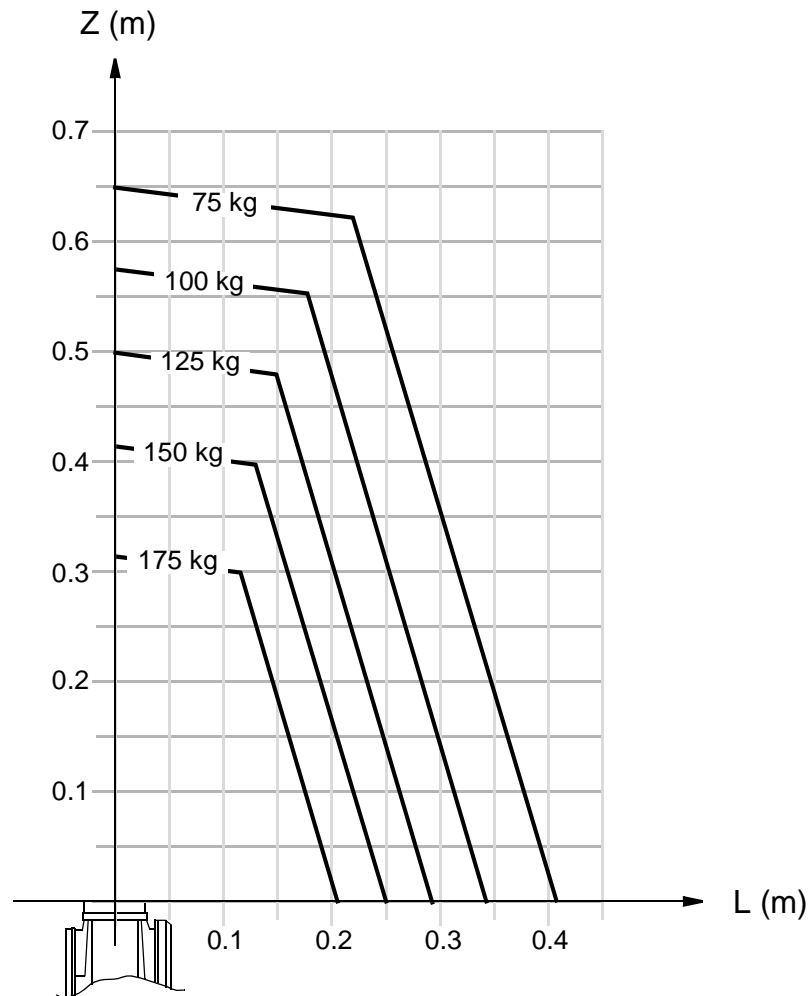

The load diagram is valid for $J_0 < 100 \text{ kgm}^2$.
 J_0 = the maximum component (J_{X0} , J_{Y0} , J_{Z0}) of the moment of inertia of the handling weight at its centre of gravity.

Figure 18 Maximum weight permitted for load mounted on the mounting flange at different positions (centre of gravity).

Load diagram for **IRB 6400 / 2.4-200**

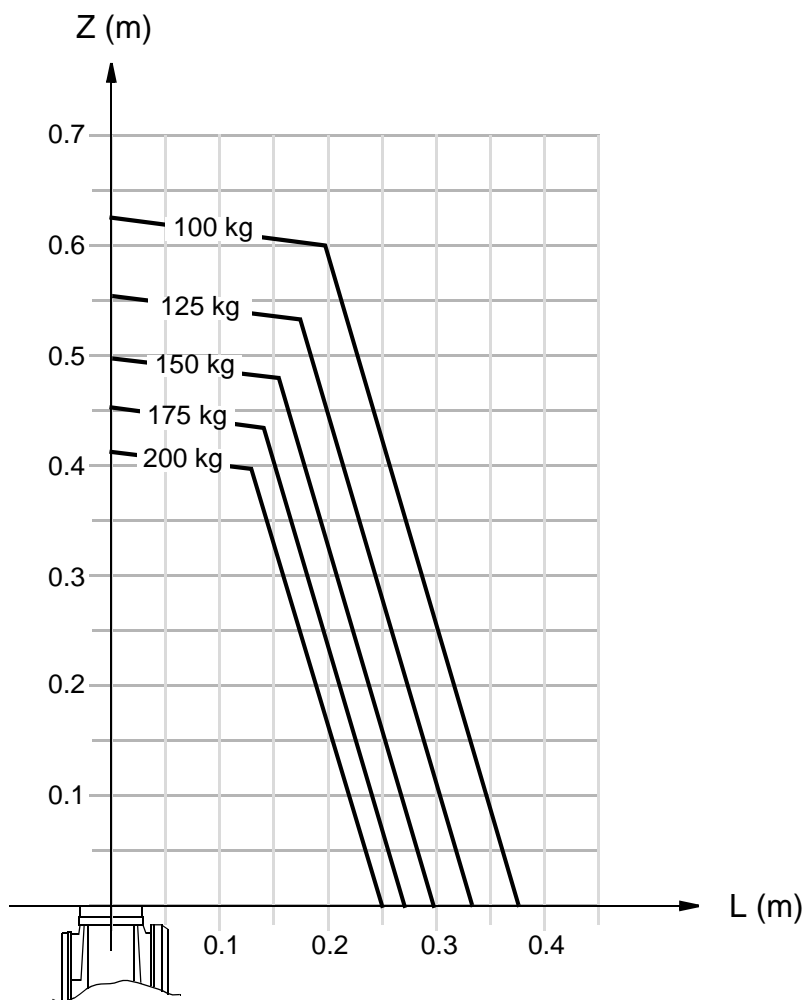

The load diagram is valid for $J_0 < 100 \text{ kgm}^2$.
 J_0 = the maximum component (J_{X0} , J_{Y0} , J_{Z0}) of the moment of inertia of the handling weight at its centre of gravity.

Figure 19 Maximum weight permitted for load mounted on the mounting flange at different positions (centre of gravity).

Technical specification

Load diagram for **IRB 6400FHD**

The load diagram is valid only when the centre line of axis 6 is within a 3D conical zone in which the max. angle from the vertical (axis vertical position) is 20 degrees. See the figure below.



Loads heavier than 200 kg must not be used outside the restricted working range of the wrist.

For loads less than 200 kg the load diagram for IRB 6400/2.4-200 can be used.

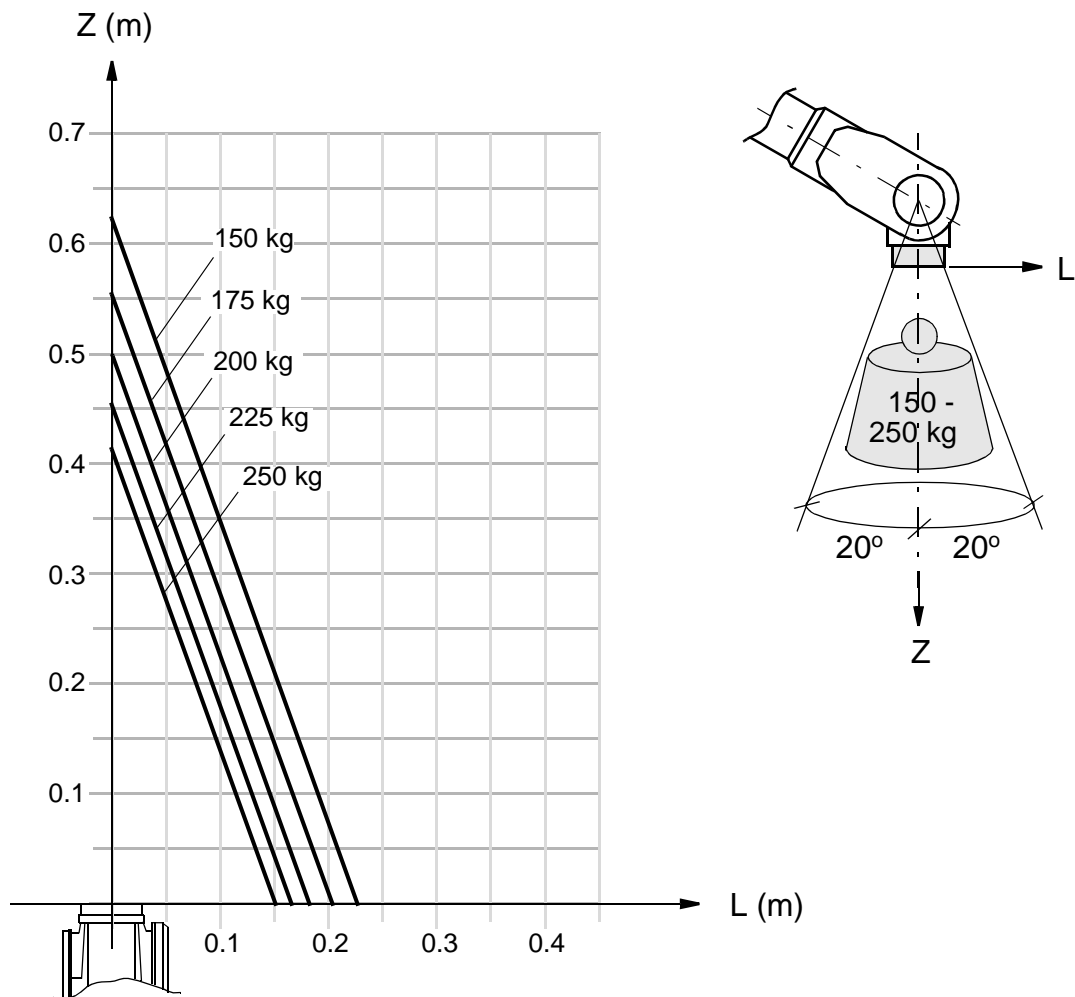

The load diagram is valid for $J_0 < 100 \text{ kgm}^2$.
 J_0 = the maximum component (J_{X0} , J_{Y0} , J_{Z0}) of the moment of inertia of the handling weight at its centre of gravity.

Figure 20 Maximum weight permitted for load mounted on the mounting flange at different positions (centre of gravity).

Load diagram for **IRB 6400PE /2.25-75**

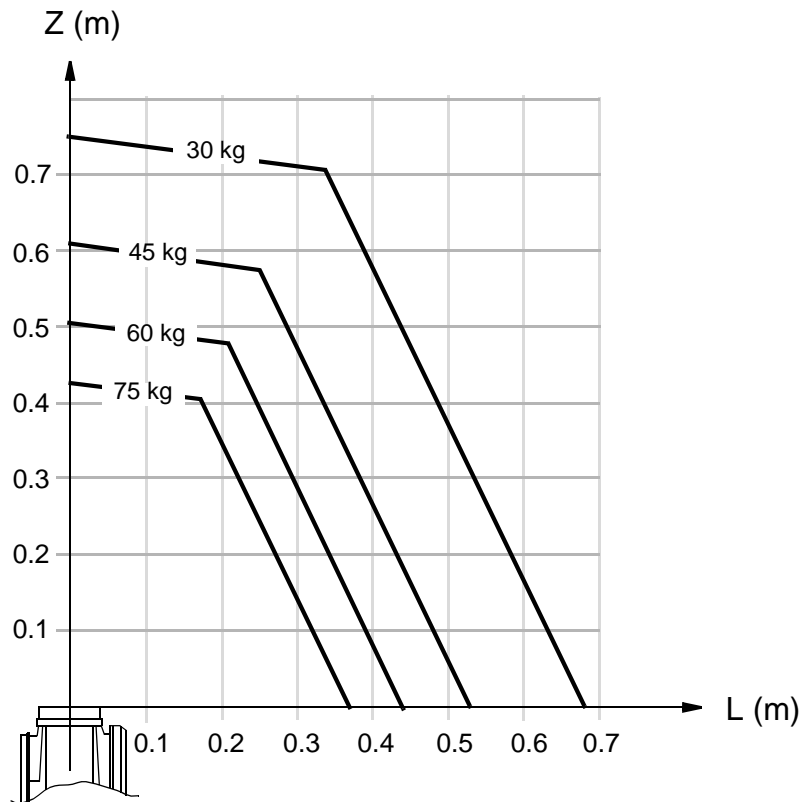

The load diagram is valid for $J_0 \leq 10 \text{ kgm}^2$.
 J_0 = the maximum component (J_{X0} , J_{Y0} , J_{Z0}) of the moment of inertia of the handling weight at its centre of gravity.

Figure 21 Maximum weight permitted for load mounted on the mounting flange at different positions (centre of gravity).

Handling capacity for IRB 6400 /2.8-120 in press-tending application

Note! Option 05x, Cooling for axis 1 motor, must be installed.

The weight and dimensions of the part and gripper are limited by the maximum static torque and moment of inertia.

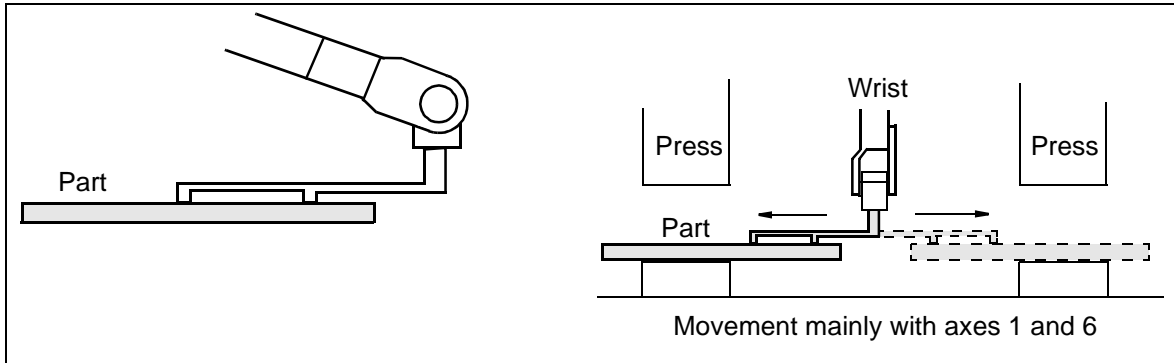

Figure 22 A-movement (inward movement).

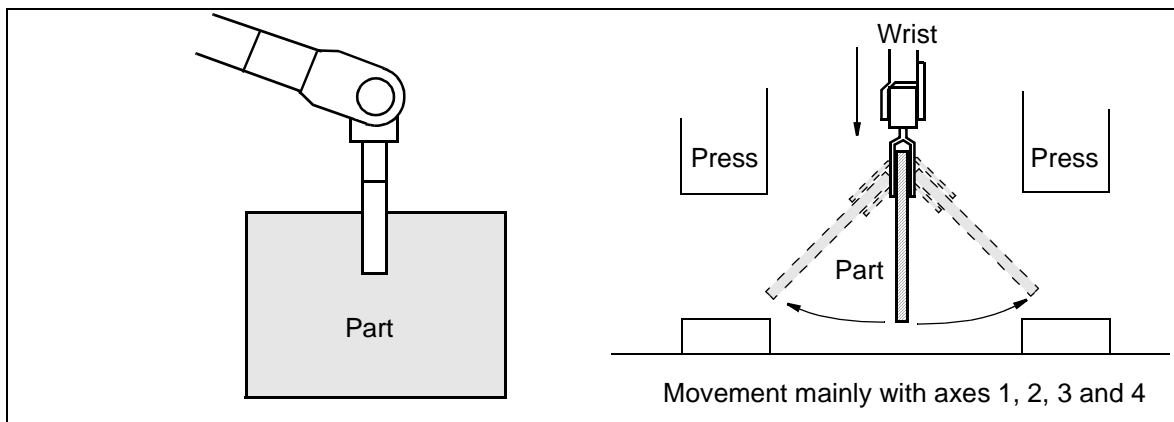

Figure 23 B-movement.

Static torque:	A-movement	Axis 5 $Ma_5 < 650 \text{ Nm}$
	B-movement	Axis 4 $Mb_4 < 650 \text{ Nm}$

Moment of inertia:	A-movement	Axis 5, $Ja_5 < 105 \text{ kgm}^2$
		Axis 6, $Ja_6 < 120 \text{ kgm}^2$
	B-movement	Axis 4, $Jb_4 < 105 \text{ kgm}^2$
		Axis 5, $Jb_5 < 120 \text{ kgm}^2$

Approximations of M and J can be calculated using the following formula:

$$Ma_5 = 9.81 \cdot (m_g \cdot r + m_p \cdot s) \quad (\text{Nm})$$

$$Mb_4 = 9.81 \cdot (m_g \cdot (r + 0.2) + m_p \cdot (s + 0.2)) \quad (\text{Nm})$$

$$Ja_5 = m_g / 12 \cdot c^2 + m_g \cdot r^2 + m_p / 12 \cdot a^2 + m_p \cdot s^2 \quad (\text{kgm}^2)$$

$$Ja_6 = m_g / 12 \cdot c^2 + m_g \cdot r^2 + m_p / 12 \cdot (a^2 + b^2) + m_p \cdot s^2 \quad (\text{kgm}^2)$$

$$Jb_4 = m_g / 12 \cdot c^2 + m_g \cdot (r + 0.2)^2 + m_p / 12 \cdot a^2 + m_p \cdot (s + 0.2)^2 \quad (\text{kgm}^2)$$

$$Jb_5 = m_g / 12 \cdot c^2 + m_g \cdot (r + 0.2)^2 + m_p / 12 \cdot (a^2 + b^2) + m_p \cdot (s + 0.2)^2 \quad (\text{kgm}^2)$$

m_g = weight of gripper (kg) m_p = weight of part (kg)

Distances a, b, c, r and s (m) are shown in Figure 24.

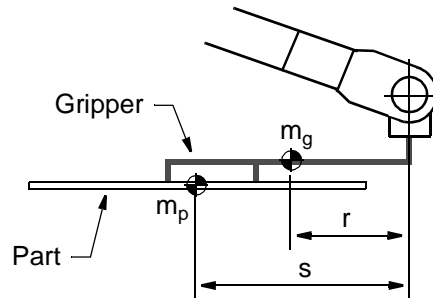

A-movement, gripper perpendicular to axis 6

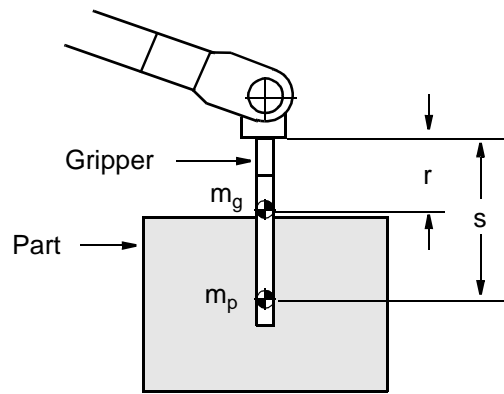

B-movement, gripper parallel to axis 6

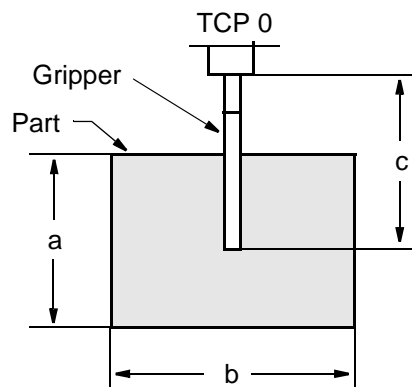

Dimensions of gripper and part

Figure 24 Distances a , b , r and s (m).

Technical specification

Process forces for IRB 6400PE /2.25-75

Max. force through the wrist centre:

- 0 to 65° relative to the vertical line, F = 5000 N
- 65 to 90° relative to the vertical line, F = 4500 N
- 90 to 115° relative to the vertical line, F = 3500 N

Max. offset force from the wrist centre:

- 3500 N when r = 100 mm.

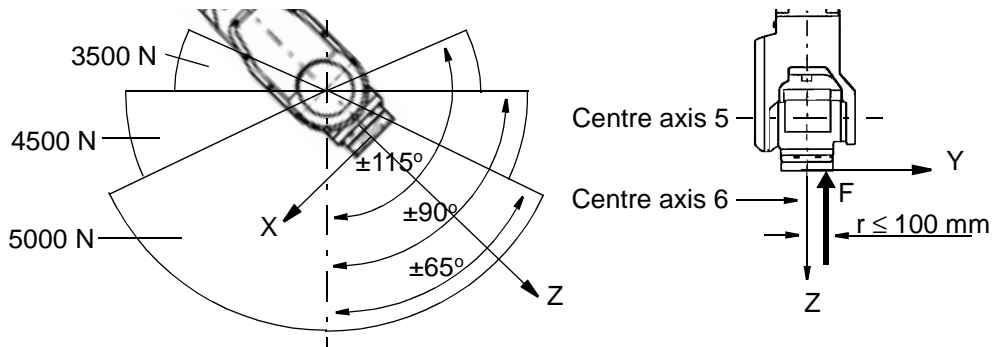

Figure 25 Max. force through the wrist centre.

The direction of force F must be parallel to the z-axis in the tool coordinate system (see Figure 9).

Time at max. force:

- < 1 second excluding rewelds
- < 3 seconds for rewelds

Due to the dynamic forces and the backward elastic deflection in the robot, the rise time for rebuilding the forces in the air cylinder must comply with the values below:

- Min. time to achieve 90% of max force:

F > 3500 N	> 0.15 sec.
F ≤ 3500 N	> 0.03 sec.
- Min. time to go from 100% load to 0% load:

F > 3500 N	> 0.1 sec.
F ≤ 3500 N	> 0.03 sec.

The angular fault from the z-axis must be less than 5°.

The distance between the weld cylinder and weld plate: 15 mm.

The number of poke points permitted per minute:

The force contact surface = 1 sec. (Cabinet temperature 45° C).

The number of points can be increased if the cabinet temperature can be decreased.

<u>Axis</u>	<u>% Torque¹</u>	<u>Number of points/minute²</u>
1	100	3-5
	75	6-8
	50	15-20
2 and 3	100	12-25
	75	26-40

¹ 100% = maximum torque load on current axis.

² The lower value applies when the current robot axis is executing large movements. The higher value applies for small movements of the current axis.

Mounting equipment

Extra loads can be mounted on the upper arm and the frame. Definitions of distances and masses are shown in Figure 26 (upper arm) and in Figure 27 and Figure 28 (frame). The robot is supplied with holes for mounting extra equipment (see Figure 29).

Upper arm

IRB 6400 /2.4-120, /2.4-150, /2.4-200, /2.8-120, IRB 6400PE /2.25-75, IRB 6400S /2.9-120 and FHD

Permitted extra load on upper arm plus the maximum handling weight (See Figure 26):

$M1 \leq 35$ kg with distance $a \leq 500$ mm, centre of gravity in axis 3 extension
or

$M2 \leq 35$ kg with distance $b \leq 400$ mm

or

$M3 \leq 10$ kg with distance $c \geq 300$ mm

If the handling weight is lower than the maximum weight, $M1$ alt. $M2$ can be increased as follows:

$M1$ (alt. $M2$) + handling weight ≤ 35 kg + max. handling weight

For example, if the handling weight for 2.4-120 is only 80 kg, $M2$ can be 75 kg.

IRB 6400 /3.0-75

Permitted extra load on upper arm (See Figure 26):

$M1 \leq 35$ kg with distance $a \leq 500$ mm, centre of gravity in axis 3 extension
or

$M2 \leq 20$ kg with distance $b \leq 400$ mm

or

$M3 \leq 5$ kg with distance $c \geq 300$ mm

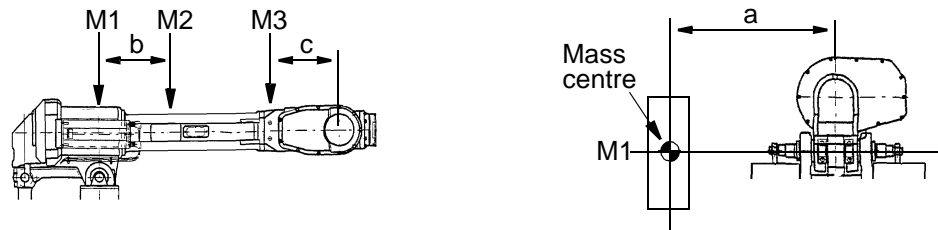

Figure 26 Permitted extra load on upper arm.

Technical specification

Frame (Hip Load)

Permitted extra load on frame is $J_H = 120 \text{ kgm}^2$.

Recommended position (see Figure 27 and Figure 28).

$$J_H = J_{H0} + M4 \cdot R^2$$

where J_{H0} is the moment of inertia of the equipment
 R is the radius (m) from the centre of axis 1
 $M4$ is the total mass (kg) of the equipment including bracket and harness ($\leq 320 \text{ kg}$)

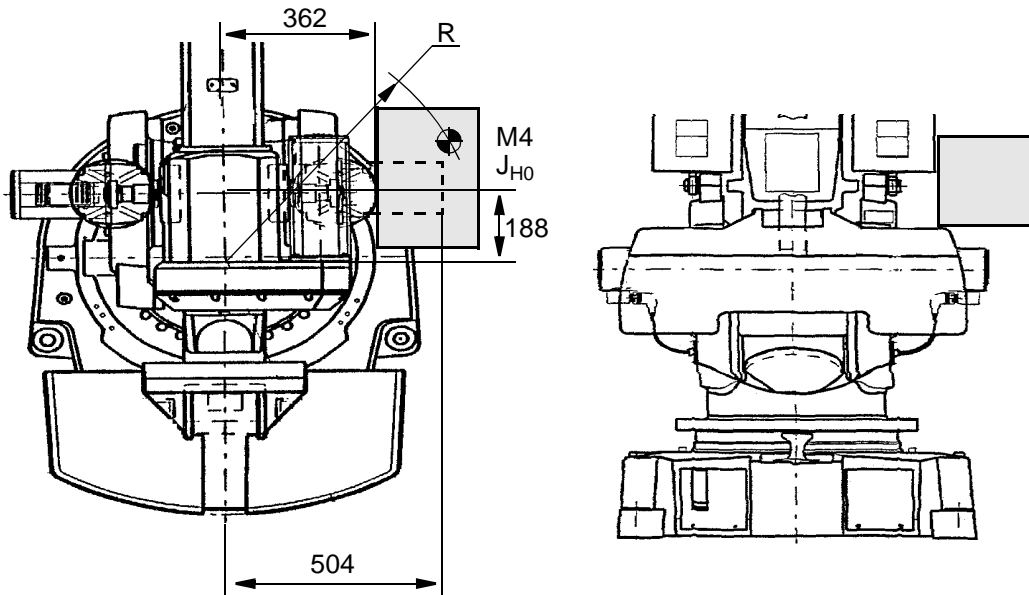

Figure 27 Extra load on frame of IRB 6400 /2.4-120, /2.4-150, /2.4-200, /2.8-120, /3.0-75, FHD and IRB 6400PE /2.25-75 (dimensions in mm).

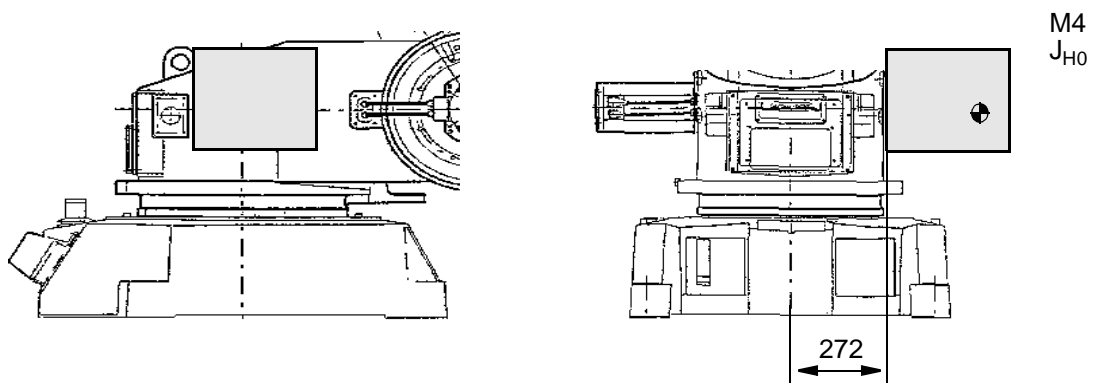

Figure 28 Extra load on frame of IRB 6400S /2.9-120 (dimensions in mm).

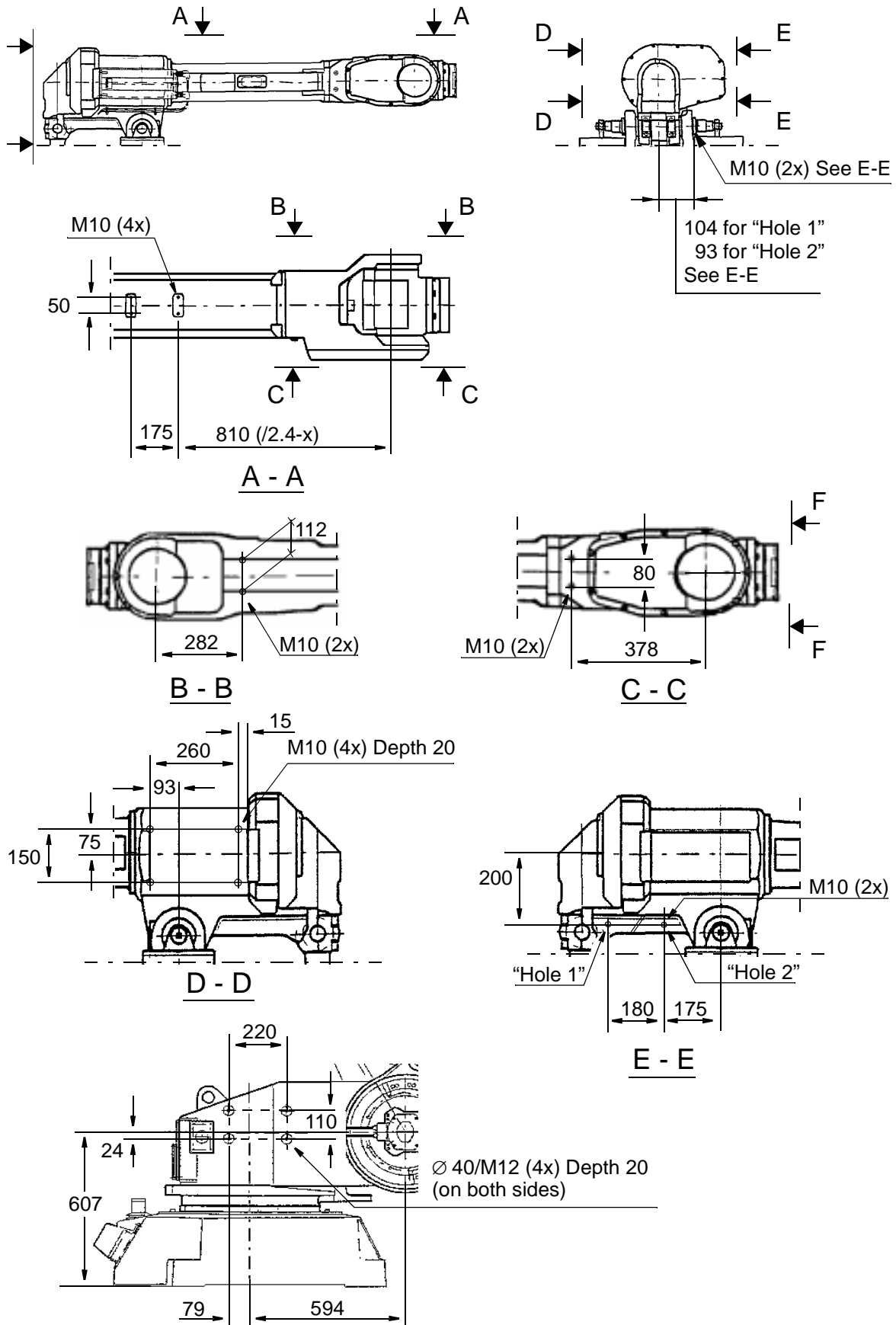

Figure 29 Holes for mounting extra equipment (dimensions in mm).

Technical specification

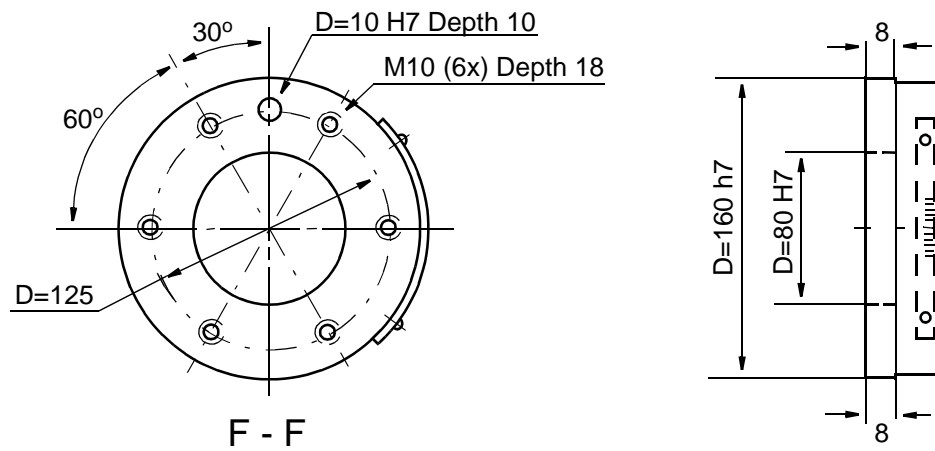

Figure 30 The mechanical interface (mounting flange) ISO 9409-1-A125 (dimensions in mm).

As an option there is an electrically insulated tool flange.
For more information see page 58 and Figure 40.

3.5 Programming

The programming language – RAPID – is a high-level application-oriented programming language and includes the following functionality:

- hierarchial and modular structure
- functions and procedures
- global or local data and routines
- data typing, including structured and array types
- user defined names on variables, routines, inputs/outputs etc.
- extensive program flow control
- arithmetic and logical expressions
- interrupt handling
- error handling
- user defined instructions
- backward execution handler

The available sets of instructions/functions are given below. A subset of instructions to suit the needs of a particular installation, or the experience of the programmer, can be installed in pick lists. New instructions can easily be made by defining macros consisting of a sequence of standard instructions.

Note that the lists below only cover BaseWare OS. For instructions and functions associated with optional software, see Product Specification RobotWare.

Miscellaneous

:=	Assigns a value
WaitTime	Waits a given amount of time
WaitUntil	Waits until a condition is met
comment	Inserts comments into the program
OpMode	Reads the current operating mode
RunMode	Reads the current program execution mode
Dim	Gets the size of an array
Present	Tests if an optional parameter is used
Load	Loads a program module during execution
UnLoad	Deletes a program module during execution

To control the program flow

ProcCall	Calls a new procedure
CallByVar	Calls a procedure by a variable
RETURN	Finishes execution of a routine
FOR	Repeats a given number of times
GOTO	Goes to (jumps to) a new instruction
Compact IF	IF a condition is met, THEN execute one instruction
IF	IF a condition is met, THEN execute a sequence of instructions
label	Line name (used together with GOTO)
TEST	Depending on the value of an expression ...

Technical specification

WHILE	Repeats as long as ...
Stop	Stops execution
EXIT	Stops execution when a restart is not allowed
Break	Stops execution temporarily

Motion settings

AccSet	Reduces the acceleration
ConfJ	Controls the robot configuration during joint movement
ConfL	Monitors the robot configuration during linear movement
VelSet	Changes the programmed velocity
GripLoad	Defines the payload
SingArea	Defines the interpolation method used through singular points
PDispOn	Activates program displacement
PDispSet	Activates program displacement by specifying a value
DefFrame	Defines a program displacement automatically
DefDFrame	Defines a displacement frame
EOffsOn	Activates an offset for an external axis
EOffsSet	Activates an offset for an external axis using a value
ORobT	Removes a program displacement from a position
SoftAct	Activates soft servo for a robot axis
TuneServo	Tunes the servo

Motion

MoveC	Moves the TCP circularly
MoveJ	Moves the robot by joint movement
MoveL	Moves the TCP linearly
MoveAbsJ	Moves the robot to an absolute joint position
MoveXDO	Moves the robot and set an output in the end position
SearchC	Searches during circular movement
SearchL	Searches during linear movement
ActUnit	Activates an external mechanical unit
DeactUnit	Deactivates an external mechanical unit
Offs	Displaces a position
RelTool	Displaces a position expressed in the tool coordinate system
MirPos	Mirrors a position
CRobT	Reads current robot position (the complete <i>robtargt</i>)
CJointT	Reads the current joint angles
CPos	Reads the current position (<i>pos</i> data)
CTool	Reads the current tool data
CWObj	Reads the current work object data
StopMove	Stops robot motion
StartMove	Restarts robot motion

Input and output signals

InvertDO	Inverts the value of a digital output signal
PulseDO	Generates a pulse on a digital output signal
Reset	Sets a digital output signal to 0
Set	Sets a digital output signal to 1
SetAO	Sets the value of an analog output signal
SetDO	Sets the value of a digital output signal after a defined time
SetGO	Sets the value of a group of digital output signals
WaitDI	Waits until a digital input is set
WaitDO	Waits until a digital output is set
AInput	Reads the value of an analog input signal
DInput	Reads the value of a digital input signal

DOutput	Reads the value of a digital output signal
GInput	Reads the value of a group of digital input signals
GOutput	Reads the value of a group of digital output signals
TestDI	Tests if a digital input signal is set
IODisable	Disables an I/O module
IOEnable	Enables an I/O module

Interrupts

ISignalDI	Orders interrupts from a digital input signal
ISignalDO	Orders interrupts from a digital output signal
ITimer	Orders a timed interrupt
IDelete	Cancels an interrupt
ISleep	Deactivates an interrupt
IWatch	Activates an interrupt
IDisable	Disables interrupts
IEnable	Enables interrupts
CONNECT	Connects an interrupt to a trap routine

Error Recovery

EXIT	Terminates program execution
RAISE	Calls an error handler
RETRY	Restarts following an error
TRYNEXT	Skips the instruction that has caused the error
RETURN	Returns to the routine that called the current routine

Communication

TPEraser	Erases text printed on the teach pendant
TPWrite	Writes on the teach pendant
TPReadFK	Reads function keys
TPReadNum	Reads a number from the teach pendant
ErrWrite	Stores an error message in the error log

System & Time

ClkReset	Resets a clock used for timing
ClkStart	Starts a clock used for timing
ClkStop	Stops a clock used for timing
ClkRead	Reads a clock used for timing
CDate	Reads the current date as a string
CTime	Reads the current time as a string
GetTime	Gets the current time as a numeric value

Mathematics

Add	Adds a numeric value
Clear	Clears the value
Decr	Decrements by 1
Incr	Increments by 1
Abs	Calculates the absolute value
Sqrt	Calculates the square root
Exp	Calculates the exponential value with the base "e"
Pow	Calculates the exponential value with an arbitrary base
ACos	Calculates the arc cosine value
ASin	Calculates the arc sine value
ATan/ATan2	Calculates the arc tangent value
Cos	Calculates the cosine value
Sin	Calculates the sine value

Technical specification

Tan	Calculates the tangent value
EulerZYX	Calculates Euler angles from an orientation
OrientZYX	Calculates the orientation from Euler angles
PoseInv	Inverts a pose
PoseMult	Multiplies a pose
PoseVect	Multiplies a pose and a vector
Round	Rounds a numeric value
Trunc	Truncates a numeric value

Text strings

NumToStr	Converts numeric value to string
StrFind	Searches for a character in a string
StrLen	Gets the string length
StrMap	Maps a string
StrMatch	Searches for a pattern in a string
StrMemb	Checks if a character is a member of a set
StrOrder	Checks if strings are ordered
StrPart	Gets a part of a string
StrToVal	Converts a string to a numeric value
ValToStr	Converts a value to a string

For more information on the programming language, see RAPID Reference Manual.

Memory

	<u>Memory size</u>	<u>Instructions¹⁾</u>
Program memory:		
Standard	2.5 MB ²⁾	7500
Extended memory 8 MB	6.0 MB ²⁾	18000
Mass storage ³⁾ :		
RAM memory Standard	0.5 MB	3000
Extended 8 MB	4 MB	31000
Diskette	1.44 MB	15000

¹⁾ Depending on type of instruction.

²⁾ Some software options reduce the program memory. See Product Specification RobotWare.

³⁾ Requires approx. 3 times less space than in the program memory, i.e. 1 MB mass memory can store 3 MB of RAPID instructions.

Type of diskette: 3.5" 1.44 MB (HD) MS DOS format.

Programs and all user-defined data are stored in ASCII format.

Memory backup

The RAM memory is backed up by two Lithium batteries. Each battery has a capacity of >12 months power off time. A warning is given at power on when one of the batteries is empty.

3.6 Automatic Operation

The following production window commands are available:

- Load/select the program.
- Start the program.
- Execute instruction-by-instruction (forward/backward).
- Reduce the velocity temporarily.
- Display program-controlled comments (which tell the operator what is happening).
- Displace a position, also during program execution (can be blocked).

3.7 Maintenance and Troubleshooting

The following maintenance is required:

- Changing filter for the transformer/drive unit cooling every year.
- Changing grease and oil every third year.
- Changing batteries every third year.
- Some additional checks every year.

The maintenance intervals depends on the use of the robot. For detailed information on maintenance procedures, see Maintenance section in the Product Manual.

3.8 Robot Motion

IRB 6400 /2.4-120, /2.4-150, /2.4-200, /2.8-120, /3.0-75, FHD and PE/2.25-75

Type of motion	Range of movement
Axis 1 Rotation motion	+180° to -180°
Axis 2 Arm motion	+70° to -70°
Axis 3 Arm motion	+105° to -28°
Axis 4*) Wrist motion	+300° to -300° +200° to -200° (PE /2.25-75)
Axis 5*) Bend motion	+120° to -120°
Axis 6 Turn motion	+300° to -300°

*) For IRB 6400FHD, see load diagram Figure 20.

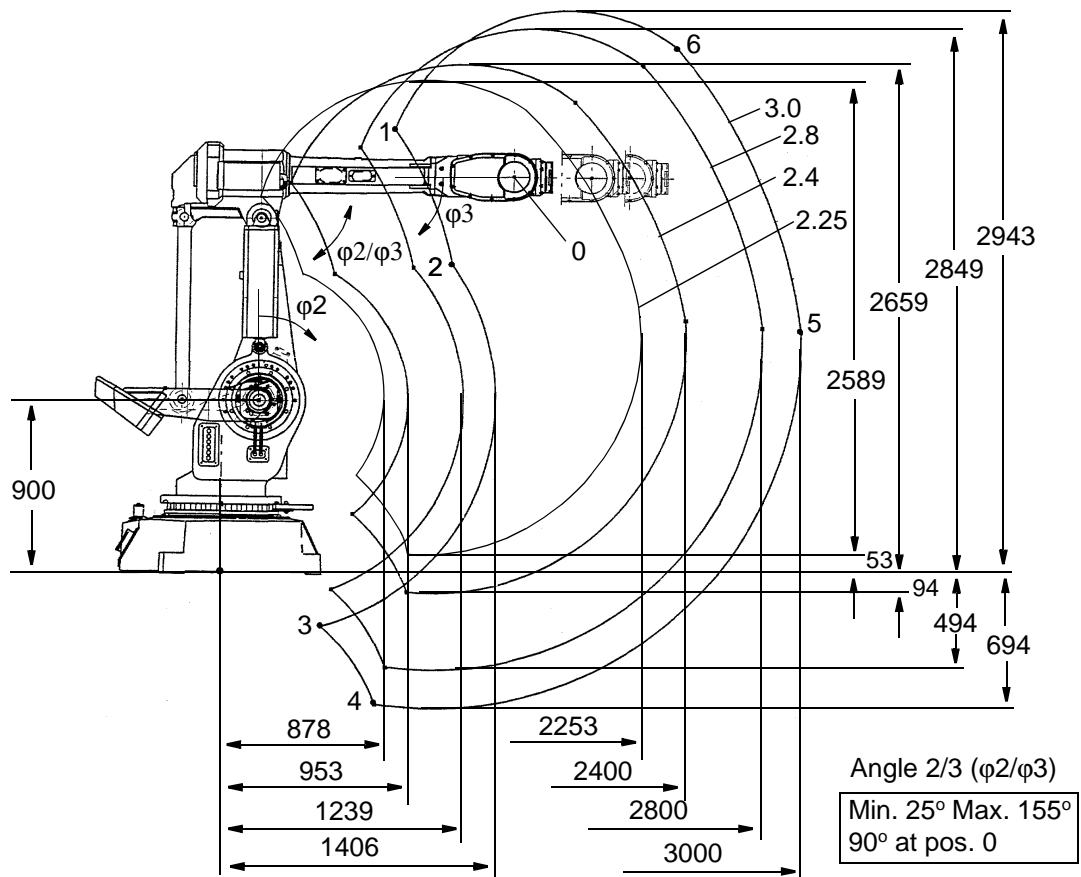

All dimensions refer to the wrist centre (mm)

pos.	Positions at wrist centre (mm)								Angle ϕ_2, ϕ_3 (degrees)		
	2.4 -120 -150 -200		2.8-120		3.0-75		PE/2.25-75		pos.	axis 2 (ϕ_2)	axis 3 (ϕ_3)
	x	z	x	z	x	z	x	z			
0	1488	2075	1892	2075	2094	2075	1338	2075	0	0	0
1	388	2034	695	2224	873	2318	205	1963	1	-70	-28
2	571	1563	974	1598	1175	1615	421	1549	2	-70	-5
3	680	314	575	-77	523	-271	718	459	3	40	105
4	962	-89	857	-479	805	-674	1000	56	4	70	105
5	2395	1336	2798	1300	2999	1283	2246	1349	5	70	5
6	1802	2467	2159	2657	2337	2752	1669	2397	6	37	-28

Figure 31 The extreme positions of the robot arm

IRB 6400S /2.9-120

Type of motion	Range of movement
Axis 1 Rotation motion	+180° to -180°
Axis 2 Arm motion	+140° to +10°
Axis 3 Arm motion	+155° to +47°
Axis 4 Wrist motion	+300° to -300°
Axis 5 Bend motion	+120° to -120°
Axis 6 Turn motion	+300° to -300°

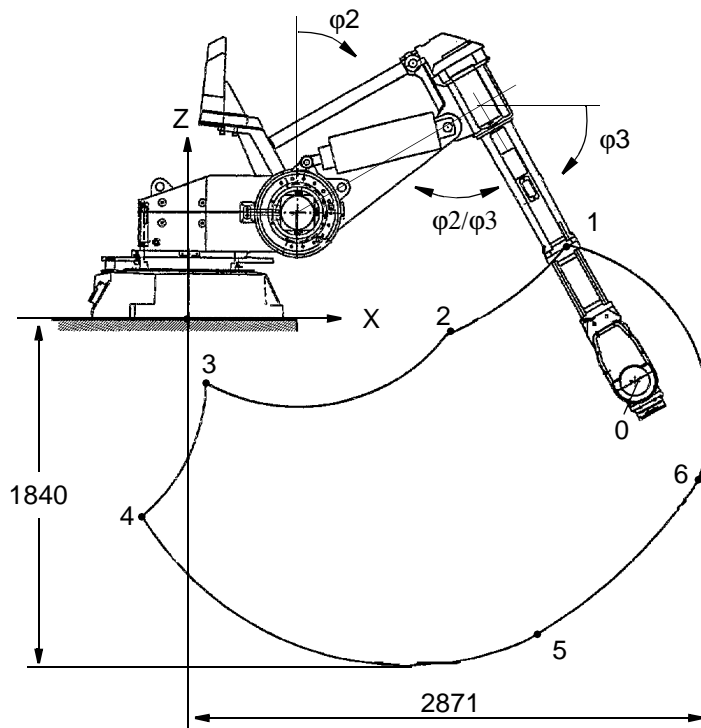

All dimensions refer to the wrist centre (mm)

Angle 2/3 (ϕ_2/ϕ_3)

Min. 25° Max. 155°
90° at pos. 0

Positions at wrist centre (mm)

pos.	x	z
0	2464	-282
1	2086	449
2	1418	-46
3	94	-317
4	-245	-1045
5	1863	-1709
6	2802	-842

Angle ϕ_2 , ϕ_3 (degrees)

pos.	axis 2 (ϕ_2)	axis 3(ϕ_3)
0	60	60
1	10	47
2	10	75
3	90	155
4	140	155
5	140	75
6	112	47

Figure 32 The extreme positions of the robot arm.

Technical specification

Performance according to ISO 9283

At rated load and 1 m/s velocity on the inclined ISO test plane with all six robot axes in motion.

Unidirectional pose repeatability:

RP = 0.1 mm (IRB 6400/2.4-120)

RP = 0.15 mm (IRB 6400/2.4-150 and IRB 6400/2.4-200)

RP = 0.2 mm (Others)

Linear path accuracy:

AT = 2.1 - 2.5 mm (IRB 6400/2.4-120)

AT = 2.5 - 3.0 mm (Others)

Linear path repeatability:

RT = 0.5 - 0.8 mm (IRB 6400/2.4-120)

RT = 0.8 - 1.4 mm (Others)

Minimum positioning time, to within 0.4 mm of the position:

0.2 - 0.3 sec. (IRB 6400/2.4-120, on 35 mm linear path)

0.6 - 0.8 sec. (IRB 6400/2.4-120, on 350 mm linear path)

0.3 - 0.5 sec. (Others, on 35 mm linear path)

0.7 - 0.9 sec. (Others, on 350 mm linear path)

The above values are the range of average test-results from a number of robots. If guaranteed values are required, please contact your nearest ABB Flexible Automation Centre.

Velocity IRB 6400 versions:

2.4-120	2.4-150	2.8-120	3.0-75	S/2.9-120	PE/2.25-75
	2.4-200				
	C/ B-150				
	FHD				

Axis no.

1	100°/s	90°/s	100°/s	100°/s	100°/s	70°/s
2	100°/s	90°/s	100°/s	100°/s	100°/s	70°/s
3	100°/s	90°/s	100°/s	100°/s	100°/s	70°/s
4	210°/s	120°/s	210°/s	210°/s	210°/s	210°/s
5	150°/s	120°/s	150°/s	150°/s	150°/s	150°/s
6	210°/s	190°/s	210°/s	210°/s	210°/s	210°/s

There is a supervision function to prevent overheating in applications with intensive and frequent movements.

Resolution

Approx. 0.01° on each axis.

3.9 External Axes

An external axis is an AC motor (IRB motor type or similar) controlled via a drive unit mounted in the robot cabinet or in a separate enclosure according to Figure 33. See Specification of Variants and Options for more information.

Resolver	Connected directly to motor shaft Transmitter type resolver Voltage ratio 2:1 (rotor: stator)
Resolver supply	5.0 V/4 kHz

Absolute position is accomplished by battery-backed resolver revolution counters in the serial measurement board (SMB). The SMB is located close to the motor(s) according to Figure 33, or inside the cabinet.

For more information on how to install an external axis, see the Product Manual - Installation and Commissioning.

Alternatively, it is possible to communicate with external drive units from other vendors. See Product Specification RobotWare.

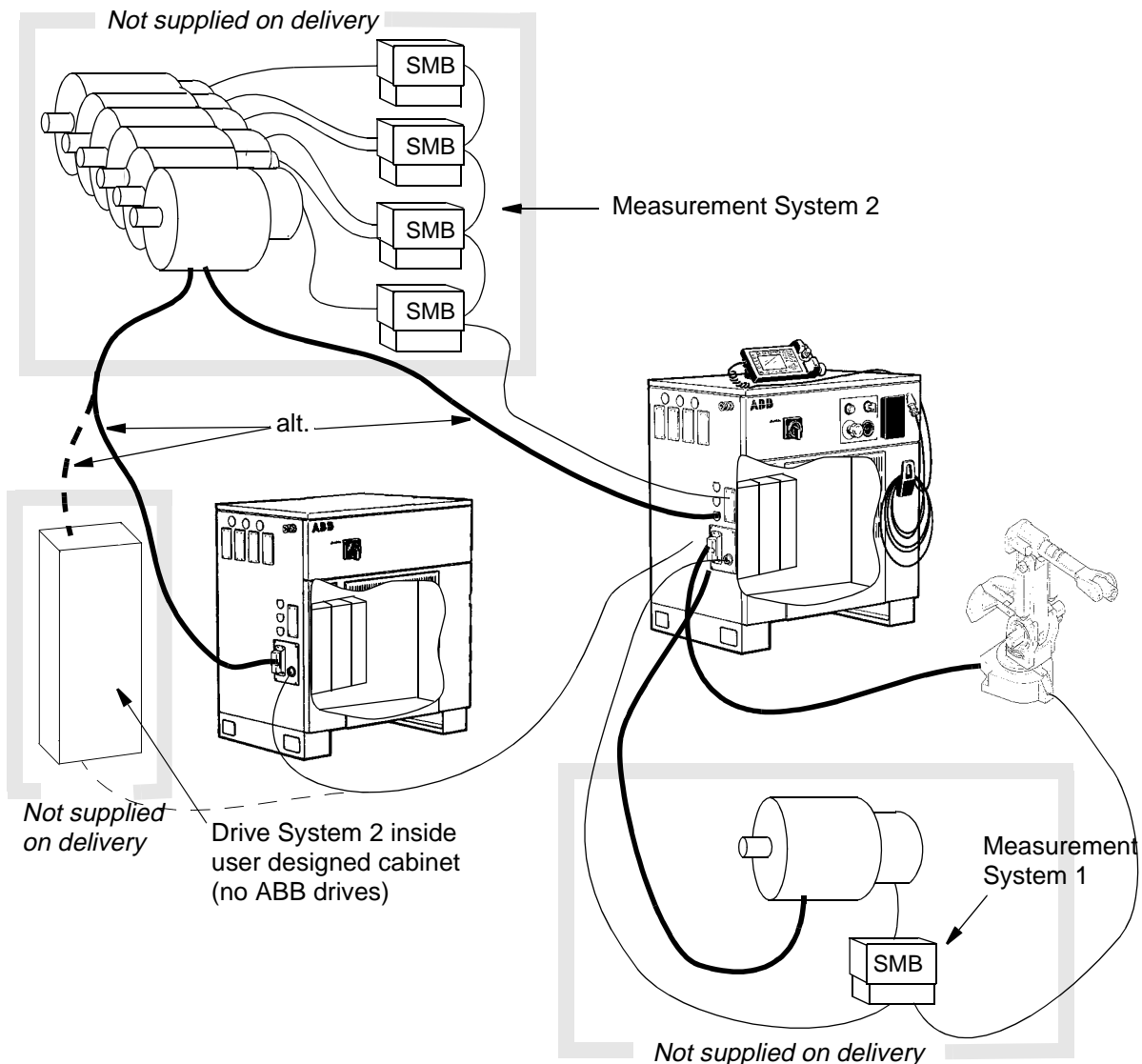

Figure 33 Outline diagram, external axes.

3.10 Inputs and Outputs

Types of connection

The following types of connection are available:

- “Screw terminals” on the I/O units
- Serial interface for distributed I/O units
- Air and signal connections to upper arm

For more detailed information, see Chapter 4: *Specification of Variants and Options*.

I/O units

Several I/O units can be used. The following table shows the maximum number of physical signals that can be used on each unit.

Type of unit	Option no.	Digital		Analog			Power supply
		In	Out	Voltage inputs	Voltage output	Current output	
Digital I/O 24 VDC	20x	16	16				Internal/External ¹
Digital I/O 120 VAC	25x	16	16				Internal/External
Analog I/O	22x			4	3	1	Internal
AD Combi I/O	23x	16	16		2		Internal/External ¹
Relay I/O	26x	16	16				Internal/External ¹
Allen-Bradley Remote I/O Slave	281	128 ²	128				
Interbus-S Slave	284-285	64 ²	64				
Profibus DP Slave	286-287	128 ²	128				
Simulated I/O ³		100	100	30	30		
Encoder interface unit ⁴	288-289	1					

1. The digital signals are supplied in groups, each group having 8 inputs or outputs.
2. To calculate the number of logical signals, add 2 status signals for RIO unit and 1 for Interbus-S and Profibus DP.
3. A non physical I/O unit can be used to form cross connections and logical conditions without physical wiring. No. of signals are to be configured. Some ProcessWares include SIM unit.
4. Dedicated for conveyor tracking only.

Distributed I/O

The total number of logical signals is 512 (inputs or outputs, group I/O, analog and digital including field buses)

Max. total no of units*	20 (including SIM units)
Max. total cable length	100 m
Cable type (not included)	According to DeviceNet specification release 1.2
Data rate (fixed)	500 Kbit/s

* Max. four units can be mounted inside the cabinet.

Technical specification

Digital outputs

120 V AC	(options 251-258)	
	Optically isolated, voltage spike protection	
	Rated voltage	120 V AC
	Output current:	max. 1A/channel, 12 A 16 channels or max. 2A/channel, 10 A 16 channels (56 A in 20 ms) min. 30mA
	Voltage range:	24 to 140 V AC
	Potential difference:	max. 500 V
	Off state leakage current:	max. 2mA rms
	On state voltage drop:	max. 1.5 V
	Time intervals: hardware	≤ 12 ms
	software	≤ 4 ms

Analog inputs	(options 221-228)	
	Voltage Input voltage:	±10 V
	Input impedance:	>1 Mohm
	Resolution:	0.61 mV (14 bits)
	Accuracy:	±0.2% of input signal

Analog outputs	(option 221-228)	
	Voltage Output voltage:	±10 V
	Load impedance:	min. 2 kohm
	Resolution:	2.44 mV (12 bits)
	Current Output current:	4-20 mA
	Load impedance:	min. 800 ohm
	Resolution:	4.88 µA (12 bits)
	Accuracy:	±0.2% of output signal

Analog outputs	(option 231-238)	
	Output voltage (galvanically isolated):	0 to +10 V
	Load impedance:	min. 2 kohm
	Resolution:	2.44 mV (12 bits)
	Accuracy:	±25 mV ±0.5% of output voltage
	Potential difference:	max. 500 V
	Time intervals: hardware	≤ 2.0 ms
	software	≤ 4 ms

Signal connections on robot arm

Signals	23	50 V, 250 mA
Power	10	250 V, 2 A
Air	1	Max. 10 bar, inner hose diameter 11 mm

CAN bus (option 04z)

Signals	12	50 V, 250 mA
Power	5	250 V, 2 A
Air	1	Max. 10 bar, inner hose diameter 11 mm

System signals

Signals can be assigned to special system functions. Several signals can be given the same functionality.

Digital outputs	Motors on/off Executes program Error Automatic mode Emergency stop Restart not possible Restart not successful Run chain closed
Digital inputs	Motors on/off Starts program from where it is Motors on and program start Starts program from the beginning Stops program Stops program when the program cycle is ready Stops program after current instruction Executes “trap routine” without affecting status of stopped regular program ¹ Loads and starts program from the beginning ¹ Resets error Resets emergency stop System reset
Analog output	TCP speed signal

1. Program can be decided when configuring the robot.

For more information on system signals, see User’s Guide - System Parameters.

3.11 Communication

The robot has two serial channels – one RS232 and one RS422 Full duplex – which can be used to communicate point to point with printers, terminals, computers and other equipment (see Figure 34).

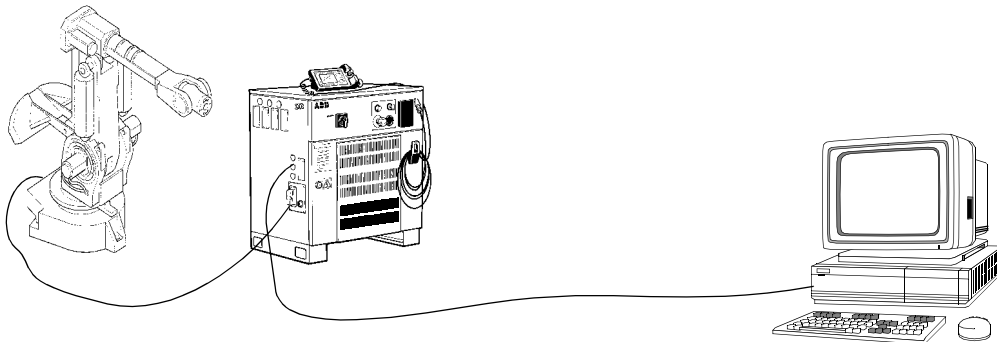

Figure 34 Serial point-to-point communication.

The serial channels can be used at speeds of 300 to 19200 bit/s (max. 1 channel with speed 19200 bit/s).

For high speed and/or network communication, the robot can be equipped with Ethernet interface (see Figure 35). Transmission rate is 10 Mbit/s.

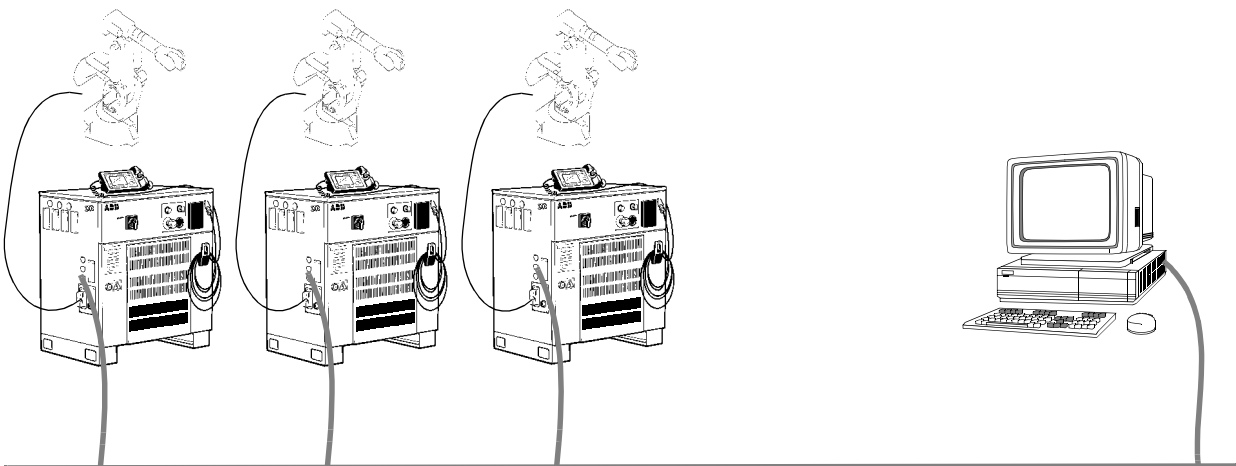

Figure 35 Serial network communication.

Character-based or binary information can be transferred using RAPID instructions. This requires the option Advanced functions, see Product Specification RobotWare.

In addition to the physical channels, a Robot Application Protocol (RAP) can be used. This requires either of the options FactoryWare Interface or RAP Communication, see Product Specification RobotWare.

4 Specification of Variants and Options

The different variants and options for the IRB 6400 are described below.
The same numbers are used here as in the Specification form. For software options, see Product Specification RobotWare.

Note Options marked with * are inconsistent with UL/UR approval.

1 MANIPULATOR Option included

022	IRB 6400 /2.4-120	
023	IRB 6400 /2.4-150	
024	IRB 6400 /2.8-120	
025	IRB 6400 /2.4-200	
026	IRB 6400 /3.0-75	
027	IRB 6400S /2.9-120	04y
028	IRB 6400PE /2.25-75	04y, 051
032	IRB 6400F /2.4-120	
033	IRB 6400F /2.4-150	
034	IRB 6400F /2.8-120	
035	IRB 6400F / 2.4-200	
036	IRB 6400F /3.0-75	
037	IRB 6400FS /2.9-120	04y
038	IRB 6400 FHD	

IRB 6400 Application, Mounting / Reach-Handling capacity

Application:	PE	Robot adapted for poke welding as in Chapter 3.4.
	F	Robot adapted for foundry environments. Degree of protection as in Chapter 3.4. The manipulator is specially painted and finished.
	HD	Heavy Duty.
Mounting:	-	Floor-mounted manipulator.
	S	Shelf-mounted manipulator.
Reach:		Specifies the max. reach at the wrist centre.
Handling capacity:		Specifies the max. handling capacity.

Manipulator colour

The manipulator is painted with ABB orange if no colour is specified.

08A- Colours according to RAL-codes.
08V

APPLICATION INTERFACE

Air supply and signals for extra equipment to upper arm

04y Integrated hose for compressed air. There is an inlet at the base (see Figure 37) and an outlet on the upper arm (see Figure 36). Connections: R1/2”.

For connection of extra equipment on the manipulator there are cables integrated into the manipulator’s cabling, and two connectors, one Burndy 23-pin UTG 018-23S and one Burndy 12-pin UTG 014-12S, on the moveable part of the upper arm.

This option is standard on the S /2.9-120 and PE /2.25-75.

04z Integrated hose for compressed air. There is an inlet at the base (see Figure 38) and an outlet on the upper arm (see Figure 36). Connections: R1/2”.

For connection of extra equipment on the manipulator there are cables integrated into the manipulator’s cabling, and three connectors on the rear part of the upper arm. The connectors are:

- one Burndy 12-pin UTG 018-12S
- one Burndy 8-pin UTG 014-8S
- one CAN DeviceNet 5-pole female connector (Ø 1”).

This option is not intended for use in Foundry versions.

CONNECTIONS OF SIGNALS

045 The signals are connected directly to the robot base to one Harting 40-pin connector (see Figure 37 and Figure 38). The cables from the manipulator base are not supplied.

671- The signals are connected to 12-pole screw terminals, Phoenix MSTB 2.5/12-ST-5.08,
674 in the controller (see Figure 46). The cable between R1.CP/CS and the controller is supplied.

CAN BUS CONNECTION

67K- 5-pin “Mini” style female contact with 7/8-16 UN-2A THD female connection thread.

67N Rotation Required. Meets ANSI/B93.55M-1981 design and intermateability requirements.

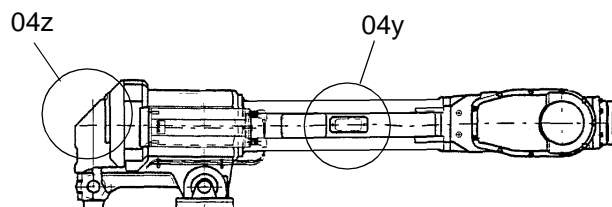

Figure 36 Connection of signals on the upper arm.

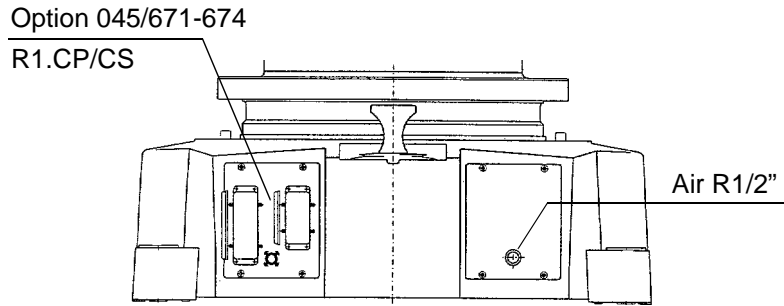

Figure 37 Option 04y, connection of signals and air to the base.

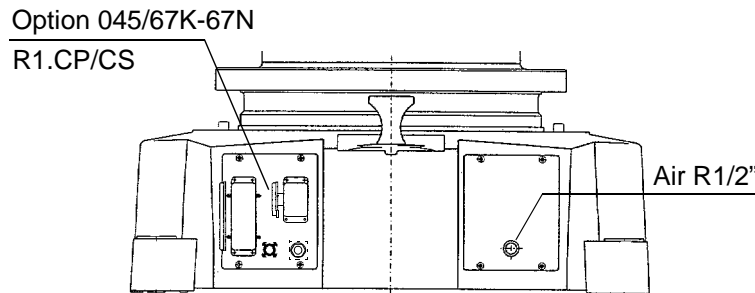

Figure 38 Option 04z, connection of signals and air to the base.

COOLING FOR AXIS 1 MOTOR

- 05x** The robot can be used for heavy duty applications on axis 1 if a cooling device is used on this axis, e.g. in press tending applications.
 The cabling included with the Spot Welding system for TG cannot be used together with this option.
 This option is not intended for use in Foundry versions.

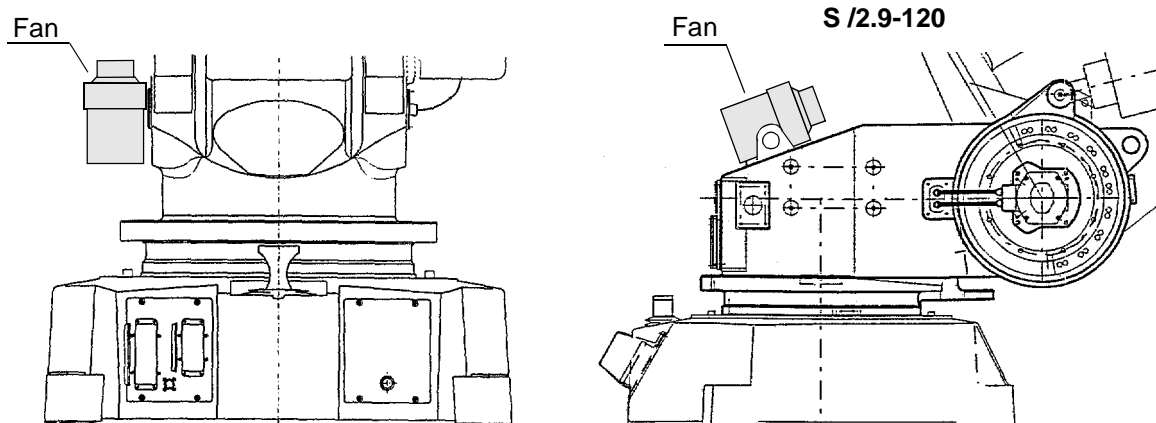

Figure 39 Location of the fan on the manipulator.

LIFTING DEVICE

- 06x** Lifting device on the manipulator for fork-lift handling is mounted at delivery.
 Lifting eyes for use with an overhead crane are integrated as standard.

Specification of Variants and Options

BRAKE RELEASE COVER

- 055** Protective cover over push-buttons on brake release unit.
Always included for Foundry versions.

INSULATED FLANGE

- 089** Electrically insulated tool flange. In case of an electrical fault in the spot welding equipment mounted on the tool flange, the tool flange withstands dangerous voltage (100V AC during 60 seconds or 300V AC during 10 seconds) in non water applications without passing it further to electronics in the robot and controller.
See Figure 40.

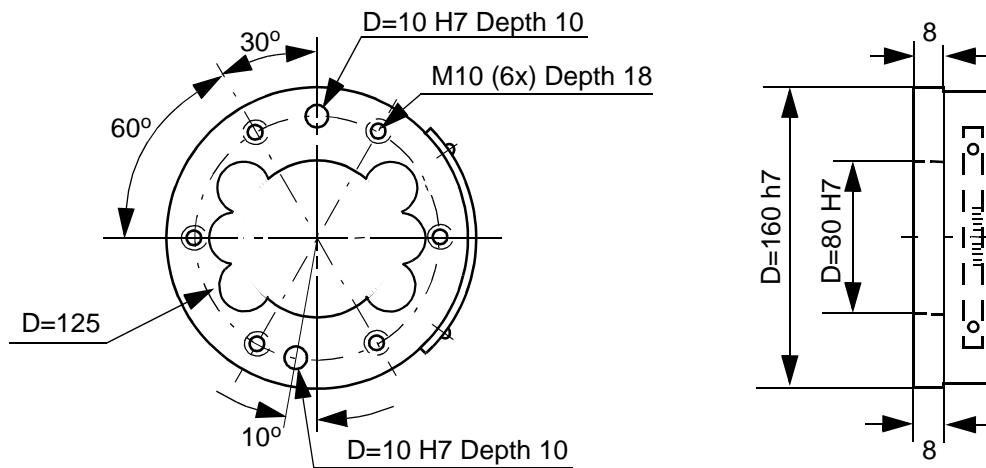

Figure 40 The mechanical interface of the insulated flange (dimensions in mm).

SAFETY LAMP

- 691** A safety lamp with an orange fixed light can be mounted on the manipulator.
The lamp is active in MOTORS ON mode.
The safety lamp is required on a UL/UR approved robot.

DRESSING

- 919** Mounting of extra equipment, e.g. tool system on robot before delivery, ordered from ABB Flexible Automation Sweden/Dpt U.

POSITION SWITCH

Position switches indicating the position of one or two of the main axes. Rails with separate adjustable cams are attached to the manipulator. The cams, which have to be adapted to the switch function by the user, can be mounted in any position in the working range for each switch.

The position switch device is delivered as a kit to be assembled when installing the robot. Assembly instruction is included.

Note! This option may require external safety arrangements, e.g. light curtains, photocells or contact mats.

Note The switches are not recommended to be used in severe environment with sand or chips.

- 071-** The signals are connected to 12-pole screw terminals, Phoenix MSTB 2.5/12-ST-5.08, in the controller (see Figure 46). The cable between the manipulator base R1.SW (see Figure 41 and Figure 38) and the controller, is included. The cable length is the same as in option 640.

1, 2 or 3 switches indicating the position of axis 1.

Switch type: Telemecanique XCK-M1/ZCK-D16, 2 pole N/C + N/O, according to IEC 947-5-1.

- 081** 1 switch, axis 1
082 2 switches, axis 1
083 3 switches, axis 1
084 1 switch, axis 2

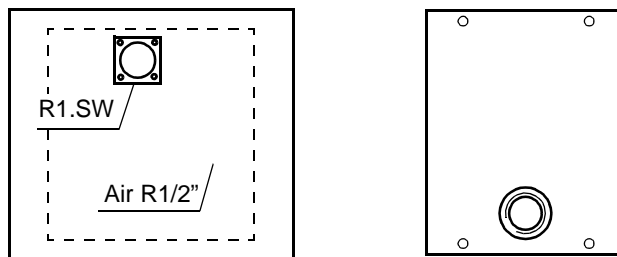

Figure 41 Connection of position switch cable to the base.

Specification of Variants and Options

WORKING RANGE LIMIT

To increase the safety of the robot, the working range of axes 1, 2 and 3 can be restricted by extra mechanical stops.

621 Axis 1

2 stops which allow the working range to be restricted in any increment of 20°.

622 Axis 2

6 stops which allow the working range to be restricted in increments of 20°. Each stop decreases the motion by 20°. This means that the motion can be decreased by 6 x 20° from the maximum axis motion.

623 Axis 3

6 stops which allow the working range to be restricted in increments of 20°. Each stop decreases the motion by 20°. This means that the motion can be decreased by 6 x 20° from the maximum axis motion.

2 SAFETY STANDARDS

UNDERWRITERS LABORATORY

Option 691 Safety lamp is included on UL and UR robots.

695 UL Listed, certificate on product level.

Underwriters Laboratories Inc. has tested and examined the finished complete product, i.e. manipulator and controller, and determined that the product fulfils the stipulated safety standards.

Some options marked with * are inconsistent with UL Listed.

Option 112 Standard cabinet without upper cover can not be UL Listed at delivery, it may be ordered as UL Recognized.

696 UR Recognized, certificate on component level.

Underwriters Laboratories Inc. has tested and examined the components in the product, manipulator and controller, and determined that they fulfil the stipulated safety standards.

3 CONTROL SYSTEM

CABINET SIZE

111 Standard cabinet (with upper cover).

112 Standard cabinet without upper cover. To be used when cabinet extension is mounted on top of the cabinet after delivery.
This option is inconsistent with UL approval (option 695 UL Listed).

114 With extended cover 250 mm.

The height of the cover is 250 mm, which increases the available space for external equipment that can be mounted inside the cabinet.

This option is inconsistent with UL approval (option 695 UL Listed).

115 With cabinet extension, 800 mm.

A cabinet extension is mounted on top of the standard cabinet. There is a mounting plate inside. (See Figure 42).

The cabinet extension is opened via a front door and it has no floor. The upper part of the standard cabinet is therefore accessible.

This option cannot be combined with option 142.

This option is inconsistent with UL approval (option 695 UL Listed).

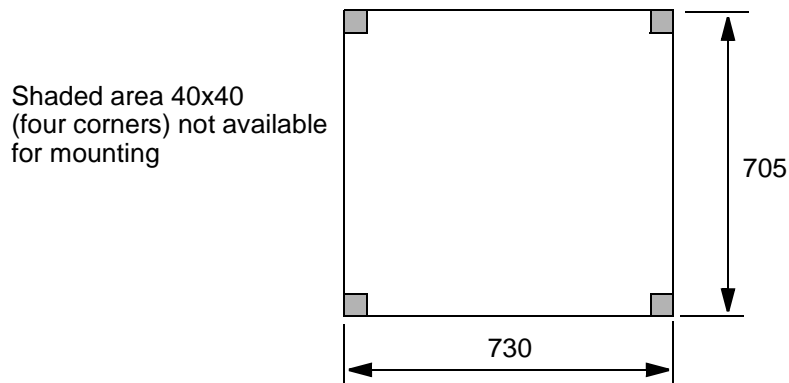

Figure 42 Mounting plate for mounting of equipment (dimensions in mm).

CABINET TYPE

121 Standard, i.e. without Castor wheels.

122 Cabinet on Castor wheels.

Specification of Variants and Options

OPERATOR'S PANEL

The operator's panel and teach pendant holder can be installed either

- 181 Standard, i.e. on the front of the cabinet, or
- 182 External, i.e. in a separate operator's unit.

All necessary cabling, including flange, connectors, sealing strips, screws, etc., is supplied.

External enclosure is not supplied.

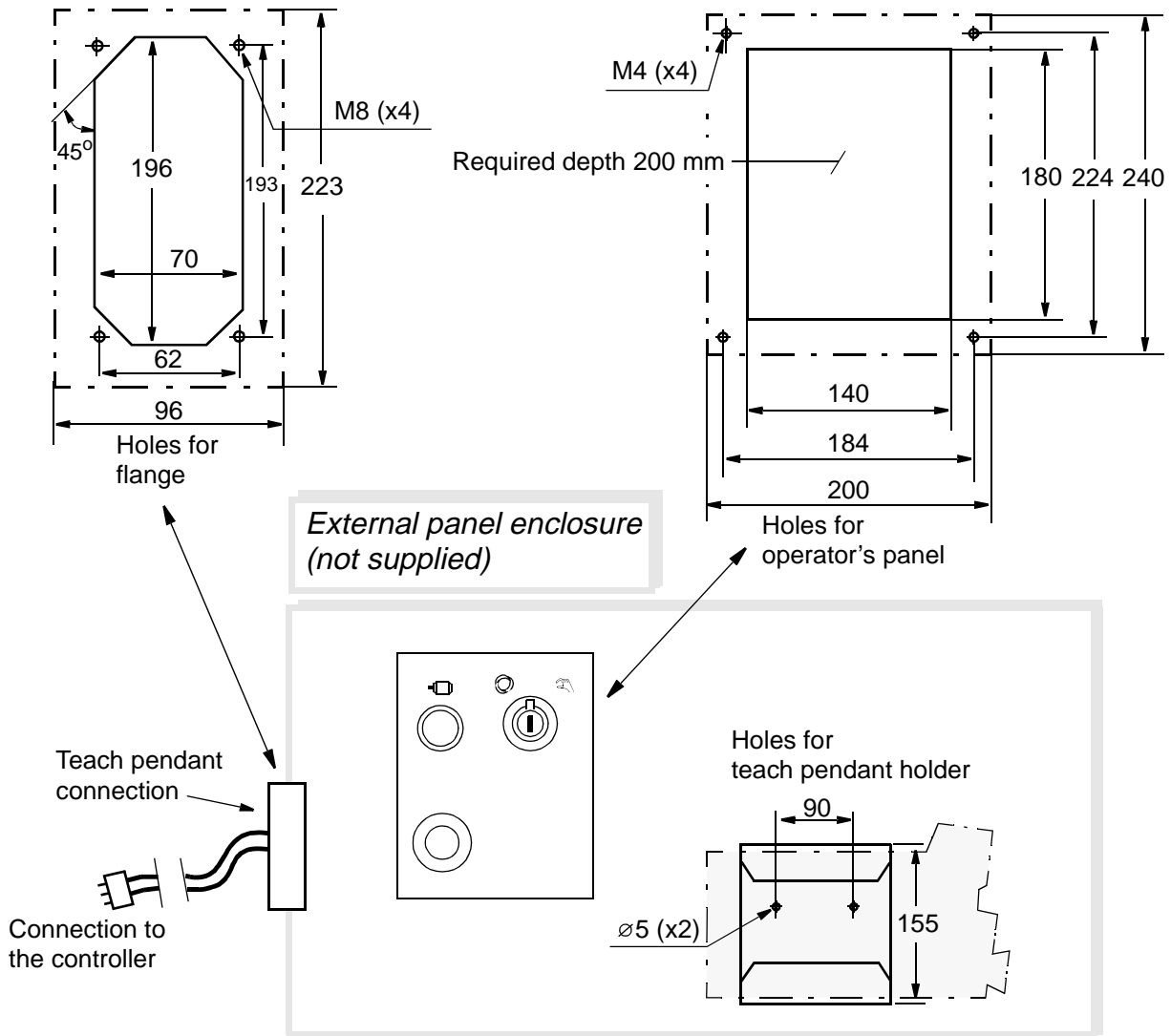

Figure 43 Required preparation of external panel enclosure (all dimensions in mm).

183 External, mounted in a box,
(see figure on the right).

Cable length

185 15 m

186 22 m

187 30 m

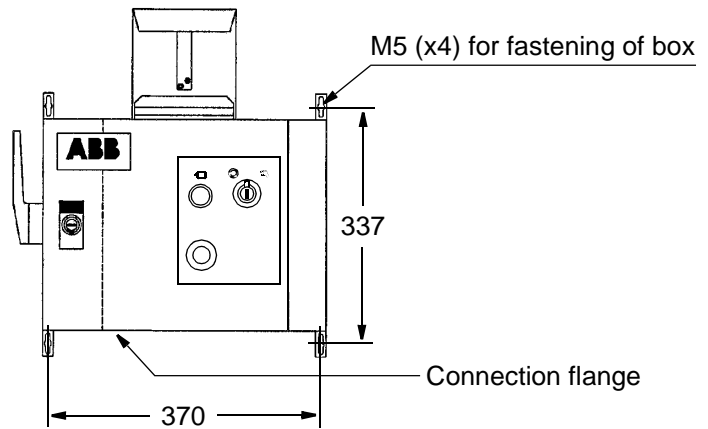

OPERATING MODE SELECTOR

193 Standard, 2 modes: manual and automatic.

191* Standard, 3 modes: manual, manual full speed and automatic.
This option is inconsistent with UL/UR approval.

DISK DRIVE COOLING

472 The disk drive normally works well at temperatures up to +40°C (104°F). At higher temperatures a cooling device for the drive is necessary to ensure good functionality. The disk drive will not deteriorate at higher temperatures but there will be an increase in the number of reading/writing problems as the temperature increases.

MAINS FILTER (EU Electromagnetic compability)

The mains filter reduces the emission of radio frequency on the incoming power, to levels below requirements in the Machinery Directive 89/392/EEC. For installations in countries not affected by this directive, the filter can be excluded.
(The option number is depending on the transformer.)

177-179 Mains filter

DOOR KEYS

461 Standard

462 DIN 3 mm

463 Square outside 7 mm

465 EMKA

Specification of Variants and Options

MAINS VOLTAGE

The robot can be connected to a rated voltage of between 200 V and 600 V, 3-phase and protective earthing. A voltage fluctuation of +10% to -15% is permissible in each connection.

151-	Transformer 1	Transformer 2	Transformer 3
174	200 V 220 V 400 V 440 V	400 V 440 V 475 V 500 V	475 V 500 V 525 V 600 V

CONNECTION OF MAINS

The power is connected either inside the cabinet or to a connector on the cabinet's left-hand side. The cable is not supplied. If option 133-136 is chosen, the female connector (cable part) is included.

- 131 Cable gland for inside connection. Diameter of cable: 11-12 mm.

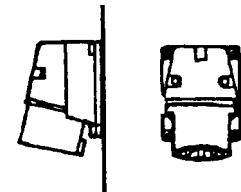

Figure 44 CEE male connector.

- 133* 32 A, 380-415 V, 3p + PE (see Figure 44).

- 134 Connection via an industrial Harting 6HSB connector in accordance with DIN 41640.
35 A, 600 V, 6p + PE (see Figure 45).

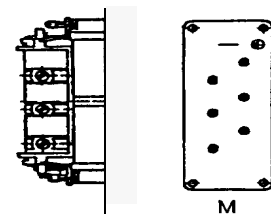

Figure 45 DIN male connector.

- 136* 32 A, 380-415 V, 3p + N + PE (see Figure 44).

MAINS SWITCH

- 141* Rotary switch in accordance with the standard in section 3.2 and IEC 337-1, VDE 0113.
- 142 Rotary switch with door interlock.
- 143 Flange disconnect in accordance with the standard in section 3.2. Includes door interlock.
- 144 Rotary switch with door interlock and servo disconnecter.
This option adds a mechanical switch to the two series connected motors on contactors.
The switch is operated by the same type of handle as the rotary mains switch.
The handle can be locked by a padlock, e.g. in an off position.

Additions to the mains switch:

147/149 Circuit breaker for rotary switch. A 16 A (transformer 2 and 3) or 25 A (transformer 1) circuit breaker for short circuit protection of main cables in the cabinet. Circuit breaker approved in accordance with IEC 898, VDE 0660.

14B

Fuses (3x15 A) for the option Rotary switch for short circuit protection of main cables in the cabinet. Interrupt capacity: 50 kA.

I/O AND COMMUNICATION

The standard cabinet can be equipped with up to four I/O units. For more details, see Technical Specification 3.10.

Note The use of I/O units and field buses can be limited because of CPU overload in the controller during motions.

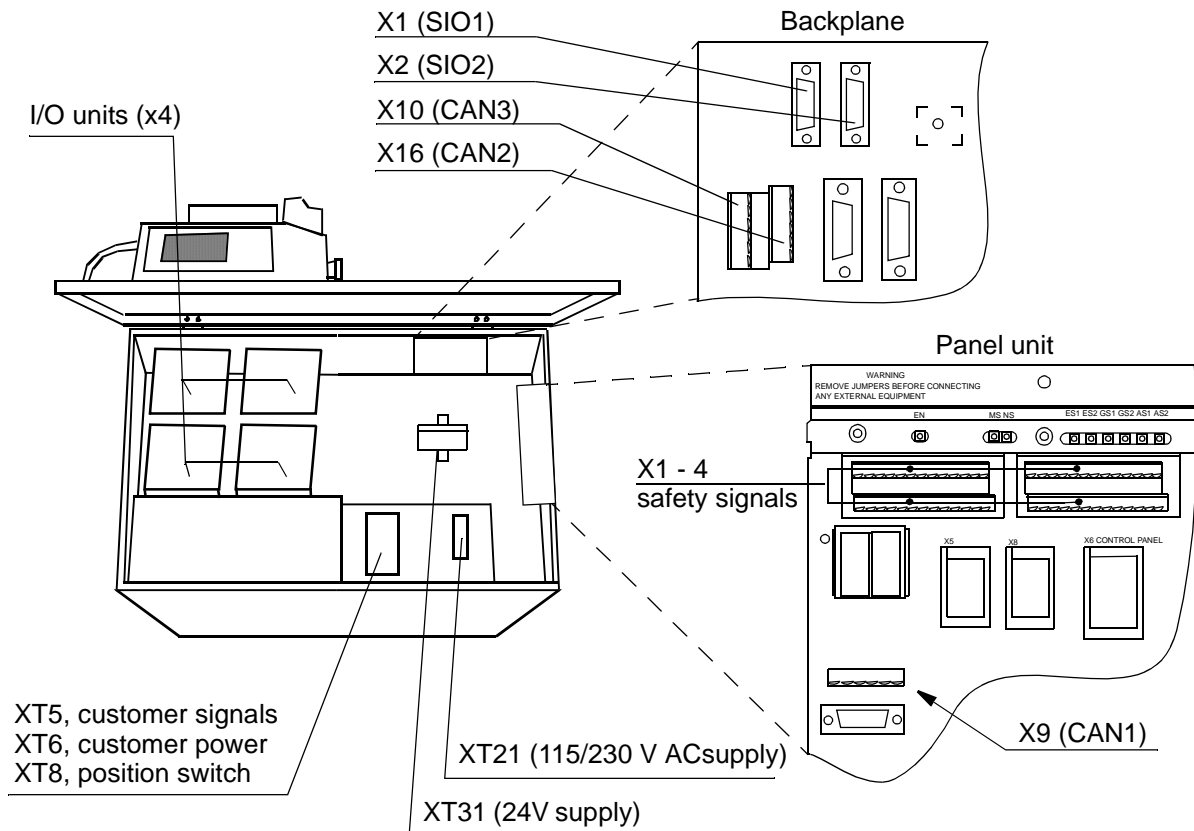

Figure 46 I/O unit and screw terminal locations.

CABINET I/O MODULES

201-208 Digital 24 VDC I/O: 16 inputs/16 outputs.

221-228 Analog I/O: 4 inputs/4 outputs.

Specification of Variants and Options

231-238 AD Combi I/O: 16 digital inputs/16 digital outputs and 2 analog outputs (0-10V).

251-258 Digital 120 VAC I/O 16 inputs/16 outputs.

261-268 Digital I/O with relay outputs: 16 inputs/16 outputs.

Relay outputs to be used when more current or voltage is required from the digital outputs. The inputs are not separated by relays.

Connection of I/O:

301 Internal connection (options 201-204, 221-224, 231-234, 251-254, 261-264)

The signals are connected directly to screw terminals on the I/O units in the upper part of the cabinet (see Figure 46).

305 External connection

Standard industrial connectors, 64-pin/socket plugs in accordance with DIN 43652, located on the left-hand side of the cabinet. Corresponding cable connectors are also supplied.

FIELD BUSES MOUNTED IN CABINET

For more details, see Technical Specification 3.9

281 Allen-Bradley Remote I/O Slave

Up to 128 digital inputs and 128 digital outputs, in groups of 32, can be transferred serially to a PLC equipped with an Allen-Bradley 1771 RIO node adapter. The unit reduces the number of I/O units that can be mounted in cabinet by one. The field bus cables are connected directly to the screw terminals on the A-B RIO unit in the upper part of the cabinet (see Figure 46).

284/285

InterBus-S Slave

Up to 64 digital inputs and 64 digital outputs per unit, in groups of 16, can be transferred serially to a PLC equipped with an InterBus-S interface. The unit reduces the number of I/O units that can be mounted in cabinet by one. The signals are connected directly to the InterBus-S-slave unit (two 9-pole D-sub) in the upper part of the cabinet, and to a 5-pole screw connector.

286/287

Profibus DP Slave

Up to 128 digital inputs and 128 digital outputs per unit, in groups of 16, can be transferred serially to a PLC equipped with a Profibus DP interface. The unit reduces the number of I/O units that can be mounted in cabinet by one. The signals are connected directly to the Profibus DP slave unit (one 9-pole D-sub) in the upper part of the cabinet, and to a 5-pole screw connector.

288/289

Encoder interface unit for conveyor tracking

Conveyor Tracking, or Line Tracking, is the function whereby the robot follows a work object which is mounted on a moving conveyor. The encoder and synchronization switch cables are connected directly to the encoder unit in the upper part of the cabinet (see Figure 46). Screw connector is included. For more information see Product Specification RobotWare.

CONNECTION OF SAFETY SIGNALS

381 Internal

The signals are connected directly to screw terminals (X1-X4) in the upper part of the cabinet (see Figure 46).

382 External

Standard industrial connectors, 64-pin plugs in accordance with DIN 43652, located on the left-hand side of the cabinet. Corresponding cable connectors are also supplied.

ADDITIONAL UNITS

I/O units can be delivered separately. The units can then be mounted outside the cabinet or in the cabinet extension. These are connected in a chain to a connector (CAN 3 or CAN 2, see Figure 46) in the upper part of the cabinet. Connectors to the I/O units and a connector to the cabinet (Phoenix MSTB 2.5/xx-ST-5.08), but no cabling, is included. Measures according to the figure below. For more details, see Technical Specification 3.10. External enclosure must provide protection class IP 54 and EMC shielding.

68A-F Digital I/O 24 V DC: 16 inputs/16 outputs.

68G-H Analog I/O.

68 I-L AD Combi I/O: 16 digital inputs/16 digital outputs and 2 analog outputs (0-10V).

68M-P Digital I/O 120 V AC: 16 inputs/16 outputs.

68Q-T Digital I/O with relay outputs: 16 inputs/16 outputs.

68U Allen Bradley Remote I/O

68V-X Interbus-S Slave

68Y-Z Profibus DP Slave

69A-B Encoder interface unit for conveyor tracking

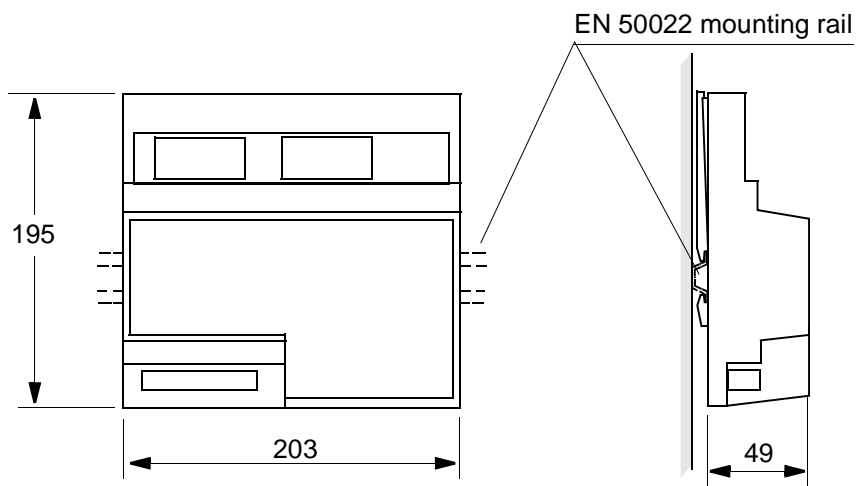

Figure 47 Dimensions for units 68A-68T.

Specification of Variants and Options

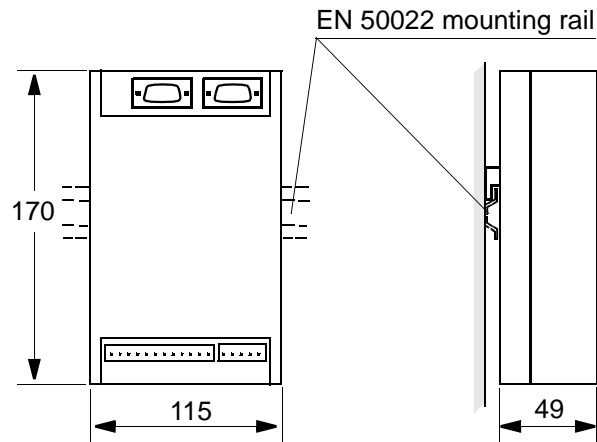

Figure 48 Dimension for units 68U-Z and 69A-B.

COMMUNICATION

As standard, the robot is equipped with one RS232 (SIO 1) and one RS422 (SIO 2) connector inside the cabinet. The signals are connected to 9-pole D-sub connectors on the backplane. See Figure 34 and Figure 46.

292 EtherNet (see Figure 35). Connectors: RJ45 and AUI on the board front.

294 DeviceNet

Connection on the left side to a 5-pole connector in accordance with ANSI.

TEACH PENDANT

631 With back lighting

Extension cable for the teach pendant:

661 10 m

This can be connected between the controller and the connector on the teach pendant's cable.

A maximum of two extension cables may be used; i.e. the total length of cable between the controller and the teach pendant should not exceed 30 m.

662 2 x 10 m

Teach pendant language:

575 English

576 Swedish

577 German

578 French

579 Spanish

580 Portuguese

581 Danish

582 Italian

583 Dutch

584 Japanese

585 Czech

EXTERNAL AXES

Drive unit mounted in cabinet

The controller is equipped with drives for external axes. The motors are connected to a standard industrial 64-pin female connector, in accordance with DIN 43652, on the left-hand side of the cabinet. (Male connector is also supplied.)

The transformer 4.5 kVA is replaced with 7.2 kVA, and the DC-link size DC1 is replaced with DC2.

391 Drive unit T

The drive unit is part of the DC-link. Recommended motor type see Figure 49.

392 Drive unit GT

A separate drive unit including two drives. Recommended motor types see Figure 49.

394 Drive unit T+GT

A combination of 391 and 392.

395 Drive unit C

The drive unit is part of the DC-link. Recommended motor type see Figure 49.

396 Drive unit C+GT

A combination of 395 and 392.

398 Prepared for GT

No drive units or cables are included, only transformer 7.2 kVA and DC link DC2.

EXTERNAL AXES MEASUREMENT BOARD

The resolver can either be connected to a serial measurement board outside the controller, or to a measurement board inside the cabinet.

386 Serial measurement board inside cabinet

Signal interface to external axes with absolute position at power on. The board is located in the cabinet and occupies one I/O unit slot. The resolvers are connected to a standard industrial 64-pin connector in accordance with DIN 43652, on the left-hand side of the cabinet.

387 Serial measurement board as separate unit

24 V POWER SUPPLY

As standard, the 24 V supply to the serial measurement board disappears almost momentarily at a power failure. To allow position control of external high speed (> 3000 rpm) motors during the power failure braking intervals, a power supply unit with extended 24 V capacity can be installed.

388 Standard power supply unit

389 Extended power supply unit

Specification of Variants and Options

EXTERNAL AXES - SEPARATE CABINET

If more external axes than in option 390 are to be used, an external cabinet can be supplied. The external cabinet is connected to one Harting connector (cable length 7 m) on the left-hand side of the robot controller.

Door interlock, mains connection, mains voltage and mains filter according to the robot controller. One transformer 7.2 kVA, and one mains switch are included.

37N-O Drive unit GT, for 4, or 6 motors. Recommended motor types see Figure 49.

37Q Drive unit ECB, for 3 or 6 motors. Recommended motor types see Figure 49.

37V Drive unit GT + ECB

37X Drive unit GT + GT + ECB

Drive unit data	Max current	Rated current	Motor type ¹
U	11 - 55A _{rms}	24A _{rms}	M, L
G	6 - 30A _{rms}	16A _{rms}	S, M, L
T	7,5 - 37A _{rms}	20A _{rms}	S, M, L
E	4 - 19A _{rms}	8,4A _{rms}	
C	2,5 - 11A _{rms}	5A _{rms}	
B	1,5 - 7A _{rms}	4A _{rms}	

1. Motors from ABB Flexible Automation/System Products.

Types: S=small ($T_N=1,7$ Nm), M=medium ($T_N=5$ Nm), L=large ($T_N=12$ Nm)

Figure 49 Motor selecting table.

EQUIPMENT

Manipulator cable, internal connectors

641- The cables are connected directly to the drive units inside the cabinet via a cable
644 gland on the left-hand side of the controller.

Manipulator cable, external connection

651- The cables are connected to 64-pin standard industrial connectors in accordance with
654 DIN 43652, located on the left-hand side of the controller and on the base of the manipulator.

655 7 m, metal braided

656 15 m, metal braided

SERVICE OUTLET

Any of the following standard outlets with protective earthing can be chosen for maintenance purposes.

The maximum load permitted is 500 VA (max. 100 W can be installed inside the cabinet).

- 421*** 230 V mains outlet in accordance with DIN VDE 0620; single socket suitable for Sweden, Germany and other countries.
- 422*** 230 V in accordance with French standard; single socket.
- 423*** 120 V in accordance with British standard; single socket.
- 424** 120 V in accordance with American standard; single socket, Harvey Hubble.
- 425*** Service outlet according to 421 and a computer connection on the front of the cabinet. The computer connection is connected to the RS232 serial channel.

POWER SUPPLY

- 431** Connection from the main transformer.
The voltage is switched on/off by the mains switch on the front of the cabinet.
- 432** Connection before mains switch without transformer.
Note this only applies when the mains voltage is 400 V, three-phase with neutral connection and a 230 V service socket.
Note! Connection before mains switch is not in compliance with some national standards, NFPL 79 for example.
- 433** Connection before mains switch with an additional transformer for line voltages 400-500 V and with a secondary voltage of 115 V or 230 V, 2A.
Note! Connection before mains switch is not in compliance with some national standards, NFPL 79 for example.
- 439 Earth fault protection**
To increase personal safety, the service outlet can be supplied with an earth fault protection which trips at 30 mA earth current. The earth fault protection is placed next to the service outlet (see Figure 46). Voltage range: 110 - 240 V AC.

RAM MEMORY

- 402** Standard, total memory 8+8 MB
- 403** Extended memory, total 8+16 MB

EXTRA DOCUMENTATION

Product Manuals

- G11-G13** English
- G21-G23** Swedish
- G31-G33** German
- G41-G43** French
- G51-G53** Spanish

Specification of Variants and Options

G61-G63 Portuguese

G71-G73 Danish

G81-G83 Italian

G91-G93 Dutch

5 Accessories

There is a range of tools and equipment available, specially designed for the robot.

Software options for robot and PC

For more information, see Product Specification RobotWare.

Robot Peripherals

- Track Motion
- Tool System
- Motor Units
- Spot welding system for transformer gun

Accessories

6 Index

A

absolute measurement 14
accessories 73
air supply 56
Allen-Bradley Remote I/O 19, 50, 66
analog signals 19, 52
arithmetic 41
automatic mode 11
automatic operation 14, 45

B

backup
 absolute measurement 27
 memory 44
battery 44
brake release cover 58

C

cabinet extension 61
cabinet wheels 61
communication 20, 54
concurrent I/O 19
configuration 11, 19, 27
connection 71
 mains supply 64
cooling device 21
 motor 57
coordinate systems 17
cross connections 19
cursor 9

D

data typing 41
delayed safeguarded space stop 25
DeviceNet 68
diagnostics 15
digital signals 19, 51
diskette 44
display 26
distributed I/O 50
door keys 63
dressing 59
drive units 69, 70

E

editing
 position 13
 programs 13
emergency stop 8, 9, 25
enabling device 8
 display 9
Encoder interface unit 50, 66
equipment
 mounting 37
 permitted extra load 37
error handling 41
event routine 14
execution handler 41
extended cover 60
extended memory 44
external axes 19, 49
external panel 62
extra equipment
 connections 56

F

Fire safety 9
fly-by point 12
function keys 26
functions 41

H

hold-to-run control 9
humidity 27

I

I/O 19, 50
I/O units 50
incremental jogging 18
inputs 19, 50
installation 11, 27
instructions 41
insulated flange 58
Interbus-S Slave 50, 66
interrupt 19
interrupt handling 41

J

jogging 18

Index

joystick 10

L

language 27

lifting device 57

lighting

 connection 71

 teach pendant 68

load 11, 28

load diagrams 29

logical expressions 41

M

mains supply 64

mains switch 64

mains voltage 63, 64

maintenance 14, 45

manipulator cable 70

manual mode 11

mechanical interface 40

memory

 backup 44

 extended 44

 mass storage 44

 RAM memory 44

menu keys 26

mirroring 13

motion 16, 46

motion keys 26

motion performance 17

mounting

 extra equipment 37

 robot 28

mounting flange 40

mounting of extra equipment 59

Multitasking 19

N

navigation keys 26

noise level 21

O

onboard calibration 58

operating mode 10

operating mode selector 10

operating requirements 27

operation 9, 26

operator dialogs 27

operator's panel 10, 62

options 55

outputs 19, 50

overspeed protection 8

P

password 13, 27

payload 11

performance 17, 48

PLC functionality 19

position

 editing 13

 execution 18

 programming 12, 18

position fixed I/O 19

position switch 59

power supply 27

printer 13

production window 14

Profibus DP Slave 50, 66

program

 editing 13

 testing 13

program displacement 42

program flow control 41

program storage 44

programming 12, 41

programming language 41

protection standards 27

Q

QuickMove 17

R

range of movement 46

RAPID 41

reduced speed 8

repeatability 48

robot calibration 58

robot motion 46

Robot Peripherals 73

robot versions 4

S

safeguarded space stop 8, 25
 delayed 8
safety 8, 25
safety lamp 9, 58
serial communication 20, 54
service 14
service outlets 70, 71
service position indicator 59
signal connections 56
signal data 51
singular points 17
soft servo 42
space requirements 21
standards 8, 25
stationary TCP 18
stop point 12
structure 7, 21
system signals 53

restricting 8, 11, 60

T

TCP 17
teach pendant 9, 26
teach pendant cable 68
teach pendant lighting 68
temperature 27
testing programs 13
transformer 64
trap routines 19
troubleshooting 14, 45
TrueMove 17

U

user-defined keys 26

V

variants 55
volume 21

W

weight 21
window keys 26
windows 9
working space

Index